



**A8 | S8**



**Dialogue: Audi QR codes**  
 Experience Audi even more directly:  
 download a QR app to your smartphone  
 and then scan the QR code or follow  
 the given link in your browser.



#### Fascination

4	Audi A8	24	Audi S8
14	Audi A8 L	32	Audi S8 plus
18	Audi A8 L W12		

#### Technology

38	Innovations	48	Performance
40	Audi ultra	50	Dynamics
42	Audi connect	52	Assistance systems
44	quattro	54	Simplicity
46	Audi Matrix LED headlights		

#### Equipment

58	Highlights	74	Audi design selection
62	Audi ultra	78	Audi exclusive
64	Engines	84	Paint finishes
66	S models	86	Wheels
70	Audi A8 L W12	88	Seats
72	Sport exterior package	90	Inlays

#### Other

92	Audi Genuine Accessories	100	Dimensions
94	The fascination of Audi	102	Index
96	Technical data		

The equipment for the vehicles illustrated in the Fascination section can be found on page 108.  
 The fuel consumption and CO<sub>2</sub> emission figures can be found from page 96 onwards.

## Design

The art of progress. Beautifully expressed in visual form. In an exceptional vehicle. The Audi A8. Awe-inspiring and sporty, staying true to one clear principle: concentration on the essential. Not a single line without a function. Distinctively structured surfaces. Exclusive materials. All finished to a supreme standard. And aspiring to something very special – brilliance down to the last detail.

**Brilliant details.**  
Flawlessly styled and timeless.

The fuel consumption and CO<sub>2</sub> emission figures can be found on page 96.

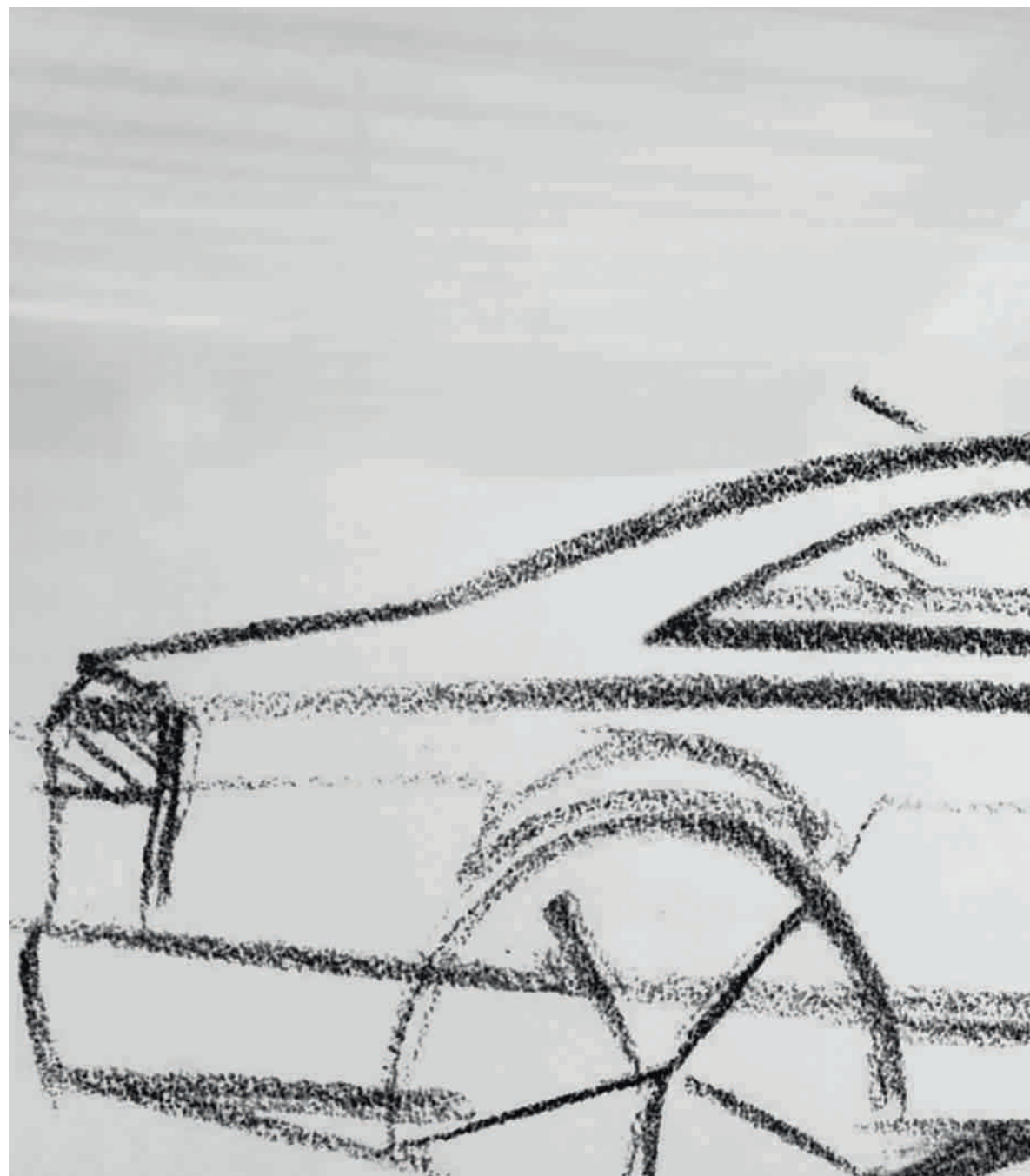

## Design



The fuel consumption and CO<sub>2</sub> emission figures can be found on page 96.



**Brilliant  
design.**  
Awe-inspiring  
and dynamic.



Design



The fuel consumption and CO<sub>2</sub> emission figures can be found on page 96.



**Brilliant  
charisma.**  
Fascinating  
and pioneering.

## Design



## Comfort



**Brilliant  
comfort.**  
Exclusive and  
authentic.





Comfort



Welcome aboard the Audi A8. A place where lavish spaciousness is blended with exquisite ambience. Choice materials lend a palpable sense of exclusivity. Top-class workmanship sets new standards. And innovative technology entertains and delights.

Such as the MMI (1) with its clear layout and elegant design. And which can be operated perfectly with the optional MMI navigation plus with MMI touch (2). Or the optional head-up display (3) that provides eye-level information at all times. The Audi A8. Designed for complete and utter comfort.



The fuel consumption and CO<sub>2</sub> emission figures can be found on page 96.





1 2

**Comfort**

The Audi A8 L. Supreme power and poise on the outside. And room in abundance on the inside. This is thanks to a wheelbase 13 centimetres longer than on the Audi A8. The result is convincing: even more exclusive space.

**Brilliant  
space.**  
Elegant and  
ample.



The fuel consumption and CO<sub>2</sub> emission figures can be found on page 96.

**Comfort**

Comfort that invites you to take a seat. Thanks to larger rear doors. And noticeably more space in the interior. The Audi A8 L. Allow yourself and your ideas all the room you need. Enjoy increased legroom in the rear. For even more relaxed travel or concentrating even better while working. Surrounded by upholstery and trim that is truly in a class of its own: unicum leather. Vegetable tanned. Breathable. Beautifully soft and yet water- and dirt-repellent, too. Full of characteristic features. Unique. Tangible. Mirroring your own personality. In every detail.

The fuel consumption and CO<sub>2</sub> emission figures can be found on page 96.



## Dynamics

Impressive performance. 368 kW of power. 625 Nm of torque. Palpable in every driving scenario. 0 to 100 km/h in 4.6 seconds. Achieved with poise and composure, thanks to the exceptionally smooth-running 12-cylinder engine. The Audi A8 L W12: proof that there truly is power in serenity.

**Brilliant  
power.  
Thrilling  
and serene.**



**Design**

Styling accents which make all the difference. Which emanate strength. Discreetly. Integrated harmoniously into the overall work of art.

Brilliant details in chrome and stainless steel. The Singleframe with close-mesh grille structure and W12 emblem. At once distinctive and elegant. Air inlets with chrome inserts. Exterior mirrors with additional integrated chrome trim. Sophisticated radiance included. Audi Matrix LED headlights as standard. And creating a particularly exclusive look are the optional 20-inch forged aluminium wheels in 15-spoke structured design with a high gloss polished finish.<sup>1</sup>





Take your seat for a journey into a different dimension. In comfort seats featuring exquisite leather upholstery. Relax. Enjoy the 4-zone deluxe automatic air conditioning. Or the soothing massage function. In the optional electrically adjustable relaxation seat in the rear. Enjoy the fascinating sensation of space. Complete with LED ambient lighting. Luxury in a new light. Unique. Unmistakeable. The Audi A8 L W12.



## Design



Charisma. Pure power. And technology of the highest standard. All combined in one of the sportiest saloons around. The Audi S8. Dynamic. Self-assured. Visibly progressive. With innovative Audi Matrix LED headlights as an option. Excitingly sporty with a new brilliance.

**Brilliant  
technology.  
Emphatically  
sporty.**



Attention to detail. With a sporty interpretation. With S8-specific 21-inch wheels as an option. Emphatically dynamic. A statement packed with power and confidence. In typical S8 fashion. Three-dimensionally architected Singleframe. Dominantly defined air inlets. The Audi S8. Expressive. Exclusive. Fascinating. A unique experience. Even before you get in.

**Brilliant  
facets.  
Strikingly  
dynamic.**



The fuel consumption and CO<sub>2</sub> emission figures can be found on page 97.

Comfort



The fuel consumption and CO<sub>2</sub> emission figures can be found on page 97.

## Dynamics

High-performance athlete with the S factor. 382 kW that respond spontaneously. And thrill. From 0 to 100 km/h in 4.1 seconds. A fascinating build-up of power. An athletic 650 Nm of torque, from just 1,700 rpm. Impressive performance. Intelligently controlled. Thanks to Audi cylinder on demand technology. Reduced fuel consumption. Lower emissions. Combined with a thoroughly brilliant performance. The Audi S8. Vorsprung durch Technik.

**Brilliant performance.**  
Breathtakingly athletic.



Self-confidence forms character. And the Audi S8 plus. A car that can rely on its strengths: technology paired with performance and a particular sense of high quality. All this means it sets the pace for the luxury segment. And makes it a vehicle for strong personalities.

**Brilliant character.**  
Brimming with  
self-confidence.



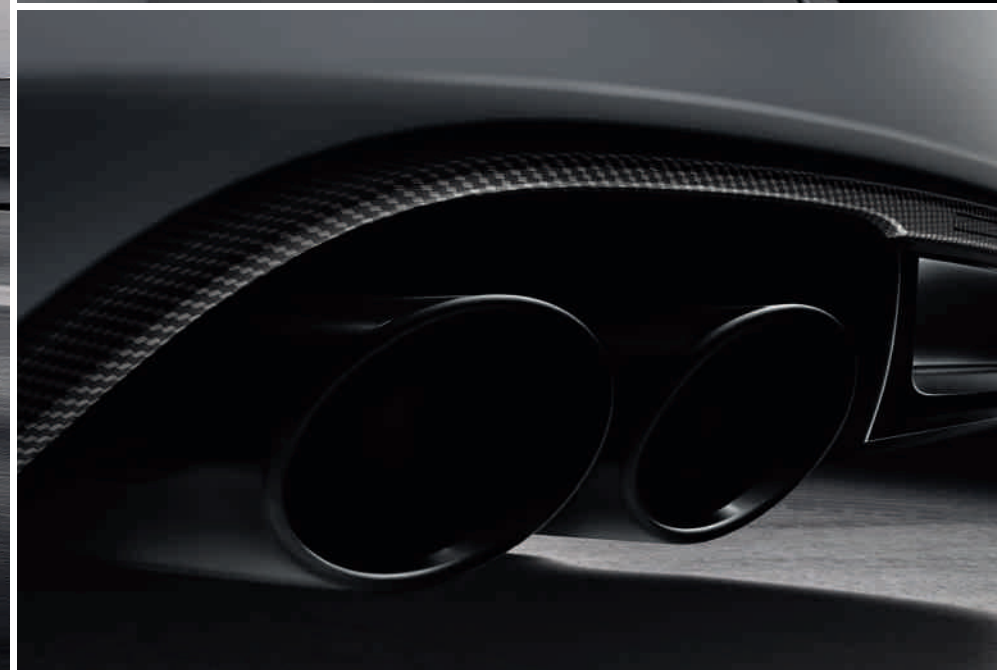

Confidence is all about attitude. Which is why the Audi S8 plus has a clear-cut, expressive design. The optional rear spoiler in carbon brings out the car's athletic character. As do the exterior mirror housings that are optionally available in carbon. And the oval tailpipes in gloss black. On the Audi S8 plus, maximum dynamism is visible from every angle.

**Brilliant expression.**  
Confident and stylish.



Audi S8 plus is from quattro GmbH.



Right from first sight, the Audi S8 plus invites you to create your own unique style. For instance with comfort sport seats in black Valcona leather with contrasting stitching in Arras red. The carbon inlays interwoven with red thread add a sporty, premium twist to the interior's craftsmanship. Perfectly consistent in every respect.

Optionally available.

**Brilliant space.  
Exclusively sporty.**

The fuel consumption and CO<sub>2</sub> emission figures can be found on page 97.

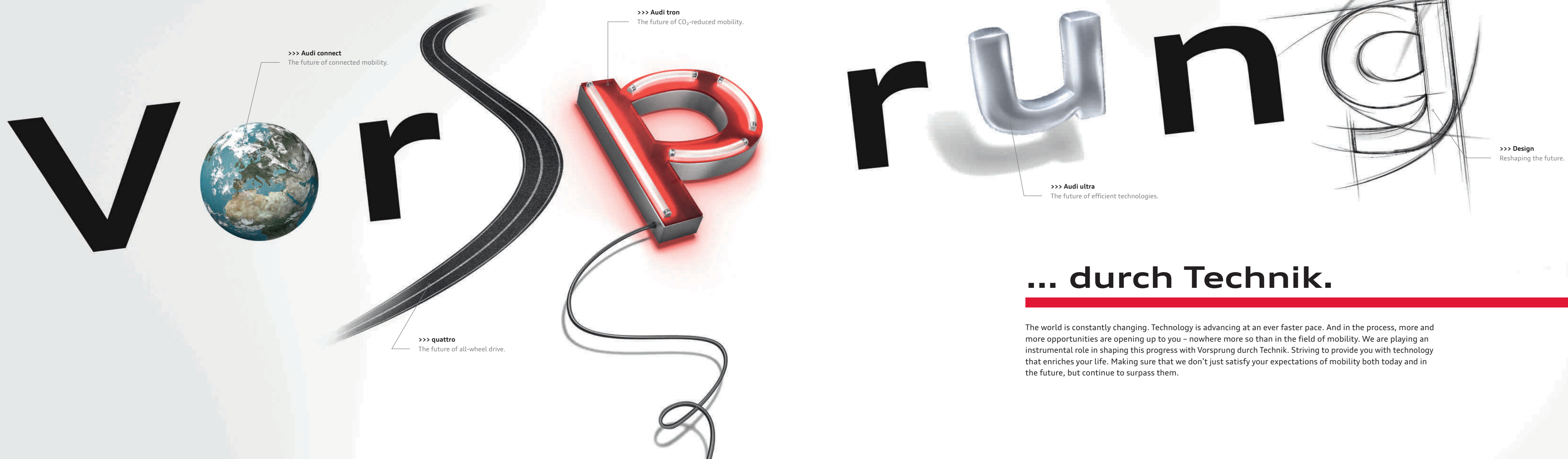

## ... durch Technik.

The world is constantly changing. Technology is advancing at an ever faster pace. And in the process, more and more opportunities are opening up to you – nowhere more so than in the field of mobility. We are playing an instrumental role in shaping this progress with Vorsprung durch Technik. Striving to provide you with technology that enriches your life. Making sure that we don't just satisfy your expectations of mobility both today and in the future, but continue to surpass them.



Audi ultra

# Perfectly combined.

## The future of efficient technologies.

Building an Audi is an extremely complicated business. And yet a simple principle applies for all models: all vehicle components interlock precisely in order to produce emission-reducing synergies. What started in accordance with this principle at the end of the 1980s with Audi lightweight construction and the revolutionary Audi Space Frame (ASF) is now known as the reversal of the weight spiral: every lightweight component has an impact on other components, which can in turn be made smaller. In this way, existing forms and materials are continuously being improved with regard to their functionality, the lowest possible weight and their production process. With the goal of building vehicles that are even more efficient and make more sparing use of resources. At the same time, more and more efficiency technologies are being built into an Audi. These include recuperation and the start-stop system. Not to mention progressive, efficient high-tech engines. For greater driving dynamics, high compression, more efficient combustion and lower CO<sub>2</sub> emissions. All this is known as Audi ultra. Today and in the future – towards CO<sub>2</sub>-reduced mobility.

### >>> Aerodynamics

Less drag, more efficiency. Thanks to the consistently aerodynamic styling of the vehicle's lines, its underbody and spoiler edges – in order to achieve the best possible form for aerodynamic efficiency. Not forgetting tyres with reduced rolling resistance. All tested in the Audi wind tunnel at up to 300 km/h.

### >>> Lightweight expertise

Less weight. More savings, power and endurance. Audi lightweight technology. What started with lightweight body construction has now made its way into nearly all areas, combining innovative materials such as aluminium, carbon and magnesium, intelligent design principles and resource-saving manufacturing processes into an overall concept.

### >>> Transmission expertise

Improved efficiency values thanks to improved transmission ratios. A higher torque output makes longer ratios possible, especially in higher gears. For powerful torque in the low engine speed range which reduces consumption – yet has no adverse effects on driving performance and sportiness.

### >>> Recuperation

Braking that leads to even more efficient driving. With brake energy recovery (recuperation). Part of the kinetic energy produced when braking and coasting is temporarily stored in the vehicle's battery and then used when accelerating. Depending on the driving cycle, this can save up to 3% of fuel.

### >>> Engine expertise

Powerfully and efficiently driven. By Audi ultra with efficiency technologies in the engine sector. Such as Audi cylinder on demand and the Audi valvelift system, which both reduce the amount of energy consumed by the engine, or clean diesel technology, which can help to reduce emissions.

## Mobility & navigation



**Point-of-interest search (POI) with voice control**  
in the Google™ database



**Traffic information online**  
dynamic route guidance with real-time traffic flow information



**Fuel prices**  
the cheapest petrol stations at your destination or in the vicinity



**Parking information**  
help with looking for car parks and multi-storeys, plus – where available – information on prices and currently vacant spaces

## Communication



**Wi-Fi hotspot**  
connects your mobile devices to the internet



If you want to experience the full diversity of Audi connect, scan this QR code using your smartphone. Or follow this link in your browser: [www.audi.com/audiconnecta8](http://www.audi.com/audiconnecta8)



**Country information<sup>2</sup>**  
Country-specific information such as whether it is compulsory to carry a high-visibility vest or display a motorway toll sticker, along with applicable speed limits, can be displayed at any time in the MMI at the push of a button.



**Navigation with Google Earth™<sup>1</sup> and Google Street View™<sup>1</sup>**  
uses high-resolution aerial and satellite images, photos and address information to guide you to your destination even more easily



**Destination entry via myAudi or Google Maps™<sup>1,3</sup>**  
If you want, you can plan your navigation destinations from your PC or using a smartphone. myAudi and Google Maps™<sup>1</sup> or the Audi MMI connect app allow individual navigation destinations to be sent to the vehicle. When you start your journey, these can easily be loaded as your destination.

**myAudi – your personal control centre**  
provides you with password-protected access to [www.audi.com/myaudi](http://www.audi.com/myaudi) where, following one-off registration, you are able to put together the services supported by Audi connect that you require, and manage and configure them from the comfort of your own home. You can also use many of these services while out and about with your smartphone (Android 4.0 or higher, iOS 6 or higher) via the Audi MMI connect app.

<sup>1</sup> Google and the Google logo are registered trademarks of Google Inc. <sup>2</sup> Service is part of the optional Audi connect including car phone.

<sup>3</sup> Destination input using Google Maps requires a Google account.

Availability, screen display and the cost of services vary depending on the country, model, device and tariff. For further legal information and notes on use, please see page 108 or visit [www.audi.com/connect](http://www.audi.com/connect). The fuel consumption and CO<sub>2</sub> emission figures can be found from page 96 onwards.

# Audi connect.

## Audi connect

## The future of connected mobility.

The world presents you with countless possibilities. Audi connect enables you to make the most of many of them in digital form directly from your Audi A8. At the push of a button. Tailored to you. Thanks to myAudi and the services supported by Audi connect in your Audi A8. In places all over the world. Intuitively, easily and conveniently.

## Infotainment



**Weather**  
forecasts and maps for the required destination.



**Audi music stream**  
access to global radio stations via smartphone app and Wi-Fi, plus access to your smartphone's media library



**News online**  
text and images about current world events



**Travel information**  
sightseeing information – with a function for importing the destination to the navigation system

Have the road completely under control, thanks to permanent distribution of the drive force to all four wheels. Variably controlled by the centre differential. Always depending on the situation. Experience handling stability, dynamism and agility as never before and combat the effects of over- and understeer with quattro with optional sport differential. For increased traction and superior propulsive power. Tame any road. And always keep your eyes set on where you're heading. In bends. On straights. Over any surface. For a fascinating experience that sticks. To the road – and in your mind. The Audi A8 – the only vehicle in its class with quattro as standard.



*quattro*  
**Stick to  
the road.**

*With quattro.*

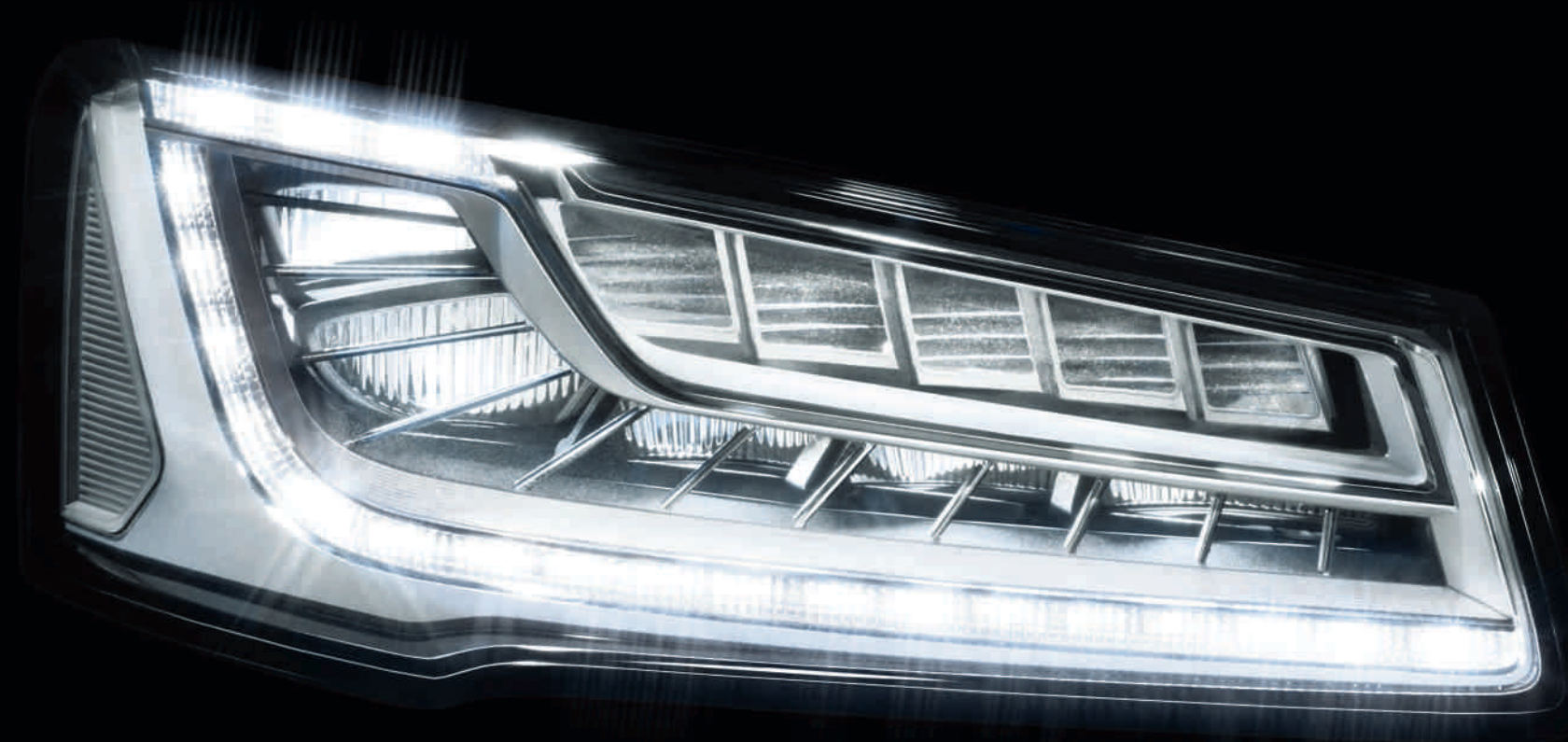

Audi Matrix LED headlights

**See well.**

Darkness is relative. The optional Audi Matrix LED headlights turn night into day. The innovative headlight technology produces a light colour similar to that of daylight. Bends are anticipated to illuminate them more clearly. Vehicles are detected and the light distribution of your Audi A8 adapts according to the situation. This is all made possible by an array of sensors and a camera. As well as dimmable LEDs in an innovative arrangement – which, incidentally, are quite a sight in their own right.



Convincingly illuminating – the video about the Audi Matrix LED headlights. Scan this QR code with your smartphone and see for yourself. Or follow this link in your browser: [www.audi.com/a8matrixledscheinwerferfilm](http://www.audi.com/a8matrixledscheinwerferfilm)



Audi Matrix LED headlights won't thrill you only at night. The innovative lighting technology is quite a spectacle during the day, too, sometimes appearing as light points, sometimes as a dynamic light strip. Individually controllable LEDs. Perfectly adapted to the situation in hand. Showing the way ahead. An impressive sight, time and time again.

The fuel consumption and CO<sub>2</sub> emission figures can be found from page 96 onwards.

**Look good.**

Performance

# Maximum power. Put to maximum use.

Every movement originates from something. Something that sets it off, an idea. The engine in your Audi A8 can also be traced back to an initial spark of inspiration: higher power with lower fuel consumption. These apparently conflicting aims are reconciled in two revolutionary drive technologies: TDI and TFSI. Get acquainted with both of them. And then opt for the drive system that you feel most moved by.



## TDI

With their combination of direct injection and turbocharging, Audi TDI engines promise exceptional performance – thanks to their high torque output over the entire engine speed range with constant power build-up. They are renowned for being fuel-efficient and for reducing emissions. But they are incredibly dynamic too – letting you get the maximum out of any road.



## TFSI

Audi TFSI engines attain a particularly high compression rate. The result: outstanding efficiency combined with optimum performance. Substituting supercharging for cubic capacity has the effect of considerably reducing engine size and weight – while performance remains as impressively dynamic as ever. For power delivery that will win you over from the word go.

## Audi cylinder on demand

Even cylinder heads can be intelligent, as Audi cylinder on demand proves. Four of the eight cylinders of the 4.0 litre V8 TFSI engine and six of the twelve cylinders of the 6.3 litre W12 FSI engine automatically shut down in the partial-load range. This helps to lower fuel consumption at the same time as reducing emissions. Without the switchover even being noticed or impairing the driving dynamics.



**>>> adaptive air suspension**

The electronically controlled air suspension acts individually at each of the four wheels and makes sure that the handling characteristics are barely affected, even when carrying heavy loads.

**>>> adaptive air suspension sport**

Depending on the mode, the sport version of the air suspension lowers the ride height by up to 10 mm compared to adaptive air suspension and has even stiffer damping.

**>>> tiptronic**

The 8-speed automatic transmission with Dynamic Shift Program (DSP) ensures faster gear changes without any perceptible break in propulsive power.

**>>> Audi drive select**

Audi drive select lets you adjust the driving characteristics of the A8 to suit your requirements. At the push of a button. Sportier, more comfortable, more balanced, more economical or even individually tailored as you please. It's entirely up to you.

**>>> Dynamic steering**

The dynamic steering enhances handling and driving comfort with speed-sensitive control of the steering ratio.

**>>> Electromechanical power steering**

The speed-sensitive power steering conveys a precise steering feel even at high speeds, helps you to countersteer and makes light work of parking.

**>>> quattro**

The permanent all-wheel-drive system distributes the drive forces to each individual wheel according to the driving situation for extra traction and dynamic performance.

**>>> quattro with sport differential**

The quattro permanent all-wheel drive with electronically controlled sport differential guarantees superb agility and thrilling driving dynamics.

**>>> Ceramic brake**

The ceramic brakes available for the front and rear axles ensure excellent braking performance in any driving situation.

Dynamics

# Dynamics

## that will take hold of you.

Get in. Buckle up. Start the engine. Wherever you're heading, enthralling driving dynamics will power you there. For as you know, the world is your oyster once you get behind the wheel of your Audi A8. You decide the direction. The driving style. The pace. And you enjoy the satisfaction of knowing you have plenty in reserve. More than enough to get the very best from every drive.

The fuel consumption and CO<sub>2</sub> emission figures can be found from page 96 onwards.

You can find out which equipment features are available as standard or optional in your model by referring to the index starting on page 102.

**>>> Audi pre sense basic**

initiates preventive occupant protection measures in the event of an impending accident.

**>>> Camera-based speed limit display**

recognises speed limits and notifies you of them via the driver information system and head-up display.

**>>> adaptive cruise control with Stop&Go function and Audi pre sense front**

monitors the traffic ahead and automatically maintains a constant distance wherever possible.

**>>> Audi Matrix LED headlights**

track the road ahead and illuminate it according to the situation with their innovative LED layout for even greater safety.

**>>> Audi active lane assist**

helps you to keep in lane by means of gentle steering intervention when lane boundary markings are detected.

**>>> Audi side assist including Audi pre sense rear**

helps you when changing lanes and initiates preventive protection measures when an impending rear-end collision is detected.

**Assistance systems**

# Wherever you're heading, peace of mind will be your constant companion.

**With the assistance systems in your Audi A8.**

Each drive is different. Yet they all have one thing in common – the feeling of being protected that you get from every Audi. All driver assistance systems in your Audi A8 help you during your journey and guarantee even greater comfort when you're on the road. Get to know the most important driver assistance systems.

**>>> Night vision assistant**

improves convenience at night thanks to its integrated thermal imaging camera, highlighting any pedestrians and larger wild animals detected.

**>>> 360 degree cameras**

provide a better overview for parking and manoeuvring by offering a choice of different camera angles all around the vehicle.

**>>> Park assist**

helps you to manoeuvre in and out of parking spaces by performing steering actions autonomously.

**>>> Audi connect**

Use all the optional services supported by Audi connect with the MMI – quickly and easily. The intuitive operation of the MMI makes accessing the internet remarkably straightforward.

**>>> Navigation**

Let yourself be guided to your destinations with even greater ease with 3D map views and a 3-dimensional display of places of interest and landmark buildings.

**>>> Car**

Control and alter driver assistance systems, vehicle settings as well as climate control and service functions quickly and easily using the MMI.

**>>> Media**

Browse through the covers of your music collection on all available media sources such as inserted SD cards, Audi music interface, CDs or DVDs.

**>>> MMI navigation plus with MMI touch**

The MMI navigation plus with MMI touch in the Audi A8 makes operating the individual components of the Multi Media Interface even easier. The touchpad integrated next to the rotary/push-button control can even be operated using just one finger.

**>>> Phone**

Make phone calls safely and easily using the hands-free facility: simply select the number to dial from your contacts in the MMI or enter the number intuitively via the MMI touch.

**Simplicity****The MMI – intelligent, individual, intuitive.**

Streamlined. Simple. Logical. The world of mobile infotainment completely redefined: the Multi Media Interface (MMI). Phoning, navigating or surfing the internet via Audi connect: all highly intuitive, highly functional and highly convenient – not least thanks to voice control. With the MMI in your Audi A8, everything will be child's play for you.





## As unique as you are. The equipment options.

Sportiness, comfort, design, functionality – whatever you demand of your Audi, it offers you a wealth of custom options. Here you will see just how much attention we pay to detail. And to quality that you can appreciate with all your senses. From exquisite inlays and the extended range of interior colours to superior quality leather: in an Audi A8 you can enjoy not just innovative technology, but also luxurious craftsmanship beyond your expectations.

## Premium quality in every detail. A quick look at your options.

The Audi A8 – an exceptional car whose diverse range of high-quality equipment will impress you. Numerous innovations, comfort and convenience features and assistance systems make each journey special. As will many other highlights – let yourself be inspired.



### 1 Relaxation seat package, rear with full-length, leather-covered centre console

2 individual seats in the rear, electrically adjustable; including pneumatic massage function as well as seat ventilation and seat heating, front and rear; luxurious relaxation seat behind the front-passenger seat with footrest on the back of the front-passenger seat backrest; with extending table in the centre console and Rear Seat Entertainment

### 2 Full-leather package

for an exclusive interior ambience thanks to extensive leather upholstery and trim for top side of instrument panel, door rails, front-seat trim and backrest covers, as well as head restraint linings front and rear in leather; includes headlining and parcel shelf in Alcantara, as well as electric sunblinds for the rear window and the rear door windows

### 3 Audi exclusive coolbox<sup>1</sup>

storage compartment for two 1 litre bottles lying down and additional storage compartment for cans and glasses; 2 possible temperature settings: -6 °C freeze, +6 °C cool; interior LED lighting

### 4 Ambient lighting

contour and ambient lighting features with a choice of 3 adjustable pre-defined colour profiles for an individually tailored and relaxed atmosphere; additional interactive individual colour profile

### 5 Audi exclusive cardan reading lights in the rear<sup>1</sup>

2 additional swivelling reading lights with LED technology, integrated into the vehicle headlining. The cone of light from reading lights can be manually adjusted

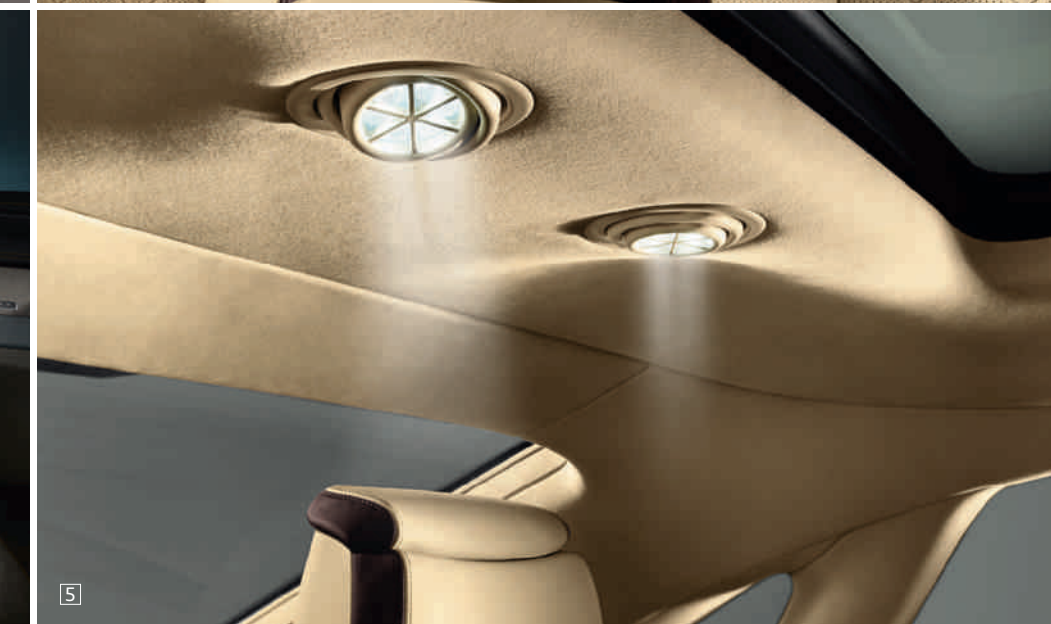

The model-specific standard and optional equipment can be found in the index from page 102 onwards. The fuel consumption and CO<sub>2</sub> emission figures can be found from page 96 onwards.

<sup>1</sup>From quattro GmbH.



**1 Assistance package including Audi pre sense plus<sup>1</sup>** combines the assistance systems parking system plus, Audi active lane assist, Audi side assist, adaptive cruise control with Stop&Go function, Audi pre sense front and Audi pre sense rear including Audi pre sense plus with maximum deceleration function

**2 MMI navigation plus with MMI touch** multimedia function and intuitive operation; navigation system with 3D map view for displaying many points of interest and city models; MMI touch for fast, intuitive operation – e. g. destination entry using handwriting recognition and moving around and zooming on the map; voice control system with whole-word entry of address in a single sentence

**3 Head-up display** Information relevant to the driver from optional equipment, such as assistance and navigation systems and warnings, are projected as required onto the windscreen in the driver's direct field of vision.

**4 Audi connect<sup>2</sup> with car phone** More convenient phoning thanks to integrated car phone and connection to the internet by means of an integrated data module. Audi connect supports available navigation, mobility, communication and infotainment services.

**5 Bang & Olufsen Advanced Sound System** captivating surround sound reproduction with 19 loudspeakers, including subwoofer; polished loudspeaker covers in aluminium and automatically extending acoustic lenses; privacy function for discreet phone calls

**6 Audi Matrix LED headlights** individually controllable, highly accurate light-emitting diodes for bright and homogeneous illumination of the road without dazzling oncoming traffic or vehicles ahead. The innovative technology combines a camera system with LED light sources and precision optics for highly adaptive light distribution.

**7 Rear Seat Entertainment** superb entertainment facility for the rear passengers, with 2 high-resolution adjustable-angle 10.2-inch LCD displays; access to numerous audio and video sources; use of navigation functions; sound output via the vehicle sound system or wireless headphones

## There's a name for maximum efficiency at Audi. The Audi A8 ultra model – the most sustainable TDI model in the range.

Technologies and measures for reducing consumption and emissions without any reduction in driving enjoyment – that's what Audi ultra stands for. The long-term aim: completely emission-free mobility. To achieve this, we are systematically continuing our development work. On more and more efficient drive technologies, for example. Such as our economical diesel engines. We award the most sustainable of these with the ultra name in the model designation, which announces: maximum efficiency ahead. Thanks to combined CO<sub>2</sub> emission values of 149 g/km. And without having to give up the dynamics typical of Audi. Experience the Audi A8 ultra model – a vehicle that redefines efficient driving.

# ultra



The **3.0 litre TDI quattro ultra engine** with 193 kW has the following CO<sub>2</sub> emission value in the combined cycle: 149 g/km.

The A8 ultra 3.0 TDI quattro model is equipped exclusively with cast aluminium wheels in 10-spoke V design in size 8 J x 18 with 235/55 R 18 tyres<sup>1</sup>. The tyres have improved rolling resistance to reduce fuel consumption.

The model-specific standard and optional equipment can be found in the index from page 102 onwards. The image shows the Audi A8 ultra 3.0 TDI quattro. The fuel consumption and CO<sub>2</sub> emission figures can be found on page 96. <sup>1</sup>You will find specifications on the technical characteristics of tyres on page 99.

## The right driving force for every personality.

No matter which Audi engine you choose, they all have high compression ratios, highly efficient combustion and outstanding efficiency. In short, they deliver more power whilst using less fuel and producing fewer emissions.



4.2 TDI

### TDI

Audi TDI engines: high torque output over the entire engine speed range – with constant power build-up. They are renowned for being fuel-efficient and for reducing emissions. The 3.0 TDI quattro, for example, has a power output of 193 kW, a regulated top speed of 250 km/h and accelerates from 0 to 100 km/h in 5.9 seconds.

- A8 ultra 3.0 TDI quattro (193 kW)
- A8 3.0 TDI quattro (193 kW)
- A8 4.2 TDI quattro (283 kW)

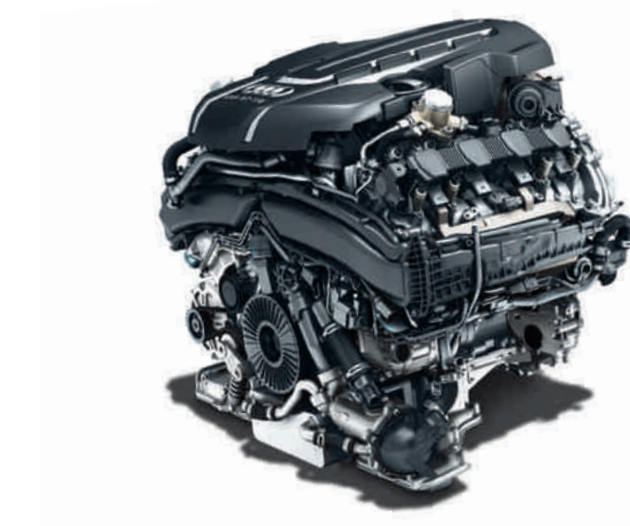

4.0 TFSI

### TFSI

The Audi TFSI engines offer outstanding efficiency and improved performance whilst at the same time retaining their dynamism. The 4.0 TFSI quattro in the Audi A8, for example, has a power output of 320 kW, enabling the car to accelerate from 0 to 100 km/h in 4.5 seconds and reach a regulated top speed of 250 km/h.

- A8 3.0 TFSI quattro (228 kW)
- A8 4.0 TFSI quattro (320 kW)
- S8 4.0 TFSI quattro (382 kW)
- S8 plus 4.0 TFSI quattro (445 kW)



6.3 FSI

### FSI

The Audi W12 engine combines superb acceleration and powerful torque with exceptionally quiet operation. The Audi A8 L W12 6.3 FSI quattro has an impressive power output of 368 kW and accelerates from 0 to 100 km/h in 4.6 seconds. Its regulated top speed is 250 km/h.

- A8 L W12 6.3 FSI quattro (368 kW)

The fuel consumption and CO<sub>2</sub> emission figures can be found from page 96 onwards.

## Sportiness that can be seen and felt. Even when stationary.

S stands for sportiness. Your Audi S8 is impressive proof of this. With extensive S-specific equipment. For a dynamic look. Sporty comfort. And superior performance. And you also have the option of further enhancing the S-factor. With optional equipment that is equally impressive to the senses.



### S8-specific standard equipment (selection)

**Cast aluminium wheels  
in 5-parallel-spoke design (S design)**  
size 9 J x 20 with 265/40 R 20 tyres<sup>1</sup>

**Brake callipers, painted black**  
with S8 logo at front

**Audi Singleframe**  
radiator protective grille in platinum grey with  
horizontal double chrome struts and S8 emblem

**Front bumper**  
in a distinctive sporty design with honeycomb-structure  
air inlet grilles and double chrome struts; includes  
aluminium-look blade

**Exterior mirror housings**  
in aluminium look

**Side sill trims**  
in body colour; distinctive sporty design

**Diffuser insert at rear**  
painted in platinum grey, edged with two-layer blade in  
aluminium look

**Exhaust tailpipes**  
dual-branch design with 2 oval chrome trims on both  
left and right

**Instrument cluster**  
with grey dials, white needles and S8 logo in the rev  
counter; dynamic ready-check feature

**Selector lever in carbon Atlas**  
with shift-by-wire technology; in conjunction with  
Audi design selection Vermont brown in piano finish,  
black

**Comfort sport seats, front**

**Upper/lower inlays**  
carbon Atlas/brushed aluminium, silver

**adaptive air suspension sport**  
with S8-specific tuning

**quattro with sport differential**  
with S8-specific tuning

### S8-specific optional equipment (selection)

**Cast aluminium wheels  
in 5-triple-spoke design (S design)**  
size 9 J x 21 with 265/35 R 21 tyres<sup>1</sup>

**Sport exhaust system**  
for an even greater sound experience; dual-branch  
design, 2 oval tailpipes each left and right;  
gloss black surrounds

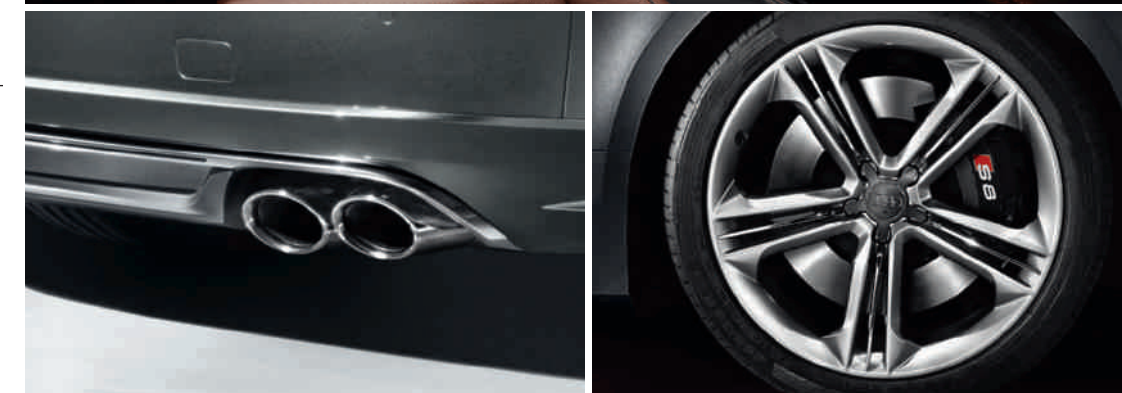

## The peak of sportiness. Outstanding in every respect.

Uncompromising in every detail. From optional equipment in carbon to the ceramic brake inspired by motor racing. A host of fascinating contrasts await you. Plus that certain something extra.



### S8 plus-specific standard equipment (selection)

**Rear spoiler**  
in body colour

**LED rear lights**  
dark-tinted, with dynamic indicators

### Audi exclusive black styling package

**Diffuser insert at rear in gloss black**  
with carbon surround

**Full-leather package in black**  
with contrasting stitching in Arras red; including Alcantara package with headlining and parcel shelf in Alcantara, black

**Bumper, front, in a sporty dynamic design**  
with side air inlet grilles in a black matt honeycomb-structure with carbon struts; includes centre blades in carbon

### Upper inlay in carbon Atlas

**Comfort sport seats**  
in Valcona leather, black, with contrasting stitching and piping in Arras red

**Audi Singleframe**  
in gloss black with radiator protective grille in black matt, gloss black double chrome struts and S8 emblem

**Dynamic steering and adaptive air suspension sport**  
with S8 plus-specific tuning

### S8 plus-specific optional equipment (selection)

**Rear spoiler in carbon**

**Exterior mirror housings**  
in a choice of brilliant black or carbon

**Paint finish in floret silver, matt effect**

**Upper inlay**  
in carbon twill, red

**Audi Sport cast aluminium wheels in 5-twin-arm design in gloss anthracite black, gloss turned finish<sup>1</sup>**  
size 9 J x 21 with 275/35 R 21 tyres<sup>2</sup>

### Dynamic package

- top speed increased to 305 km/h
- ceramic brake system
- sport exhaust system with special S8 plus tuning; dual-branch design, 2 oval gloss black trims, left and right



## Brilliant just got even more brilliant. The Audi A8 L W12.

For all those who can't get enough of A8 fascination: the Audi A8 L W12. For even more power, space and exclusivity. And equipment that leaves nothing to be desired. From standard-fitted highlights, such as the Audi Matrix LED headlights and the close-mesh honeycomb-structure radiator grille in chrome, through to the numerous custom options available on request.



### A8 L W12-specific standard equipment (selection)

Audi Matrix LED headlights

Ambient lighting

Audi Singleframe, W12-specific  
in chrome, with close-mesh honeycomb-structure grille

19" cast aluminium wheels in 5-arm design  
size 9 J x 19 with 255/45 R 19 tyres<sup>1</sup>

Comfort seats, front

Headlining and parcel shelf in Alcantara

Seat heating, front and rear

Comfort head restraints, rear

Individual rear seats, electrically adjustable

Exterior mirror housings in body colour  
with integrated chrome strip

Climate-controlled comfort/acoustic glazing

4-zone deluxe automatic air conditioning

### A8 L W12-specific optional equipment (selection)

20" forged aluminium wheels in 15-spoke structured  
design, high gloss polished finish<sup>2</sup>  
size 9 J x 20 with 265/40 R 20 tyres<sup>1</sup>

Relaxation seat package, rear  
with full-length leather-covered centre console

Extended comfort equipment, rear

Footrests, rear





## Adding a sporty flair: the A8 and A8 L sport exterior package.

Accentuate the dynamic character of your Audi A8. The sport exterior package allows you to create distinctive accents and give your vehicle a stylishly sporty flair. And if you wish, you can also add elegant high gloss black highlights by opting for the Audi exclusive black styling package<sup>1</sup>, which is available in conjunction with the sport exterior package. With, of course, features whose design and finish radiate a brilliance which is utterly in keeping with the vehicle.



### A8 and A8 L sport exterior package

Front and rear bumpers, side sill trims and side radiator grilles in a distinctive, sporty design

#### Optionally available:

Paint finish in all standard/optional equipment colours. The special paint colour Daytona grey, pearl effect is available as an option for the sport exterior package

The fuel consumption and CO<sub>2</sub> emission figures can be found from page 96 onwards.

## The Audi exclusive black styling package<sup>1</sup> for the A8 and A8 L.

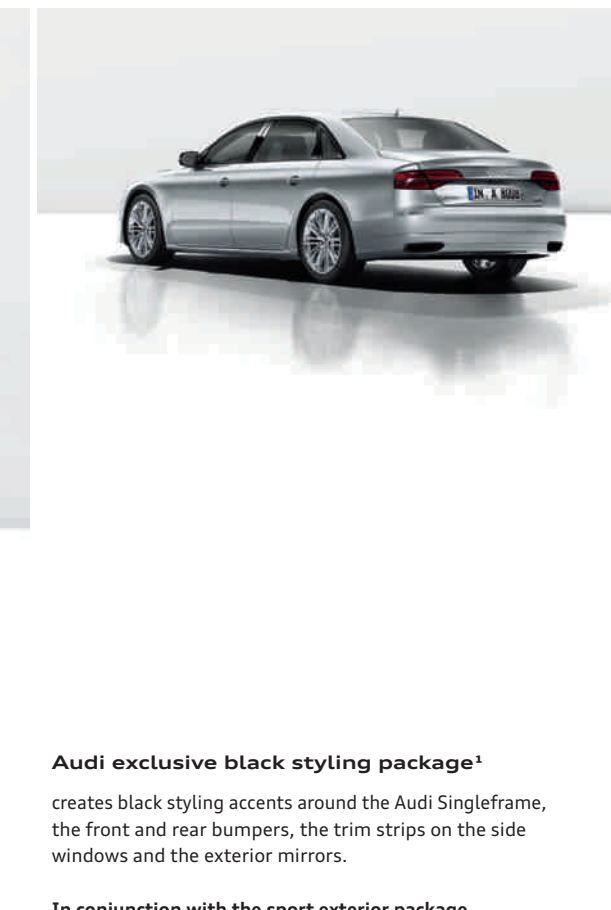

### Audi exclusive black styling package<sup>1</sup>

creates black styling accents around the Audi Singleframe, the front and rear bumpers, the trim strips on the side windows and the exterior mirrors.

In conjunction with the sport exterior package

<sup>1</sup> From quattro GmbH.

## As unmistakable as your own standards: the Audi design selection.

Audi design selection offers you an attractive pre-selection of exclusive materials and colours for the interior. Our designers have combined inlays of fine woods or carbon and brushed aluminium with exquisite leather seats featuring attractive contrasting stitching. First-class comfort functions complete the exclusive range of Audi design selection.



The fuel consumption and CO<sub>2</sub> emission figures can be found from page 96 onwards. The image shows the Audi S8.

### Audi design selection Vermont brown

The Audi design selection Vermont brown includes the following:

Comfort sport seats in Valcona leather, Vermont brown with accordion pleat, contrasting stitching and piping in granite grey

Seat belts in black

Headlining, upper pillar trim and sun visors in Alcantara, lunar silver (optionally available in Alcantara, black)

Parcel shelf in Alcantara, black

Multifunction sport leather steering wheel in 3-spoke design in black with contrasting stitching in Vermont brown; in the S8 with S-specific stitching, S8 emblem and aluminium-look shift paddles

Selector lever in leather, black; on the S8 in piano finish, black

Top side of dashboard in black with stitching in black

Underside of dashboard in black

Door armrests, centre console and knee pad in black with contrasting stitching in Vermont brown

Door trim inserts in Alcantara, black

Centre console and wood trim on the back of the front seats in fine grain ash, natural copper brown; on the S8 in piano finish, black

Carpet and floor mats in velour, black

Upper inlay in fine grain ash, natural copper brown or, on the S8 and S8 plus, in carbon twill, copper

Lower inlay in brushed aluminium, silver



The images show the Audi S8.

### Additional equipment:

Metallic paint finish; for S8 also option of pearl-effect paint finish

Comfort centre armrest, front

Seat heating, front and rear

Seat ventilation and massage function, front

Comfort head restraints, rear

4-zone deluxe automatic air conditioning

Ambient lighting

Full-leather package including headlining and parcel shelf in Alcantara as well as electric sunblinds on the rear window and on the rear door windows

Extended aluminium look in the interior

design selection emblem in the door trims



#### Audi design selection sycamore grey

The Audi design selection sycamore grey includes the following:

Comfort seats in Valcona leather, sycamore grey with accordion pleat, contrasting stitching and piping in brass gold

Seat belts in black

Headlining, upper pillar trim and sun visors in Alcantara, snow white

Parcel shelf in Alcantara, sycamore grey

Multifunction leather steering wheel in marble grey with shift paddles

Selector lever in leather, marble grey

Top side of dashboard in marble grey with contrasting stitching in sycamore grey or brass gold

Underside of dashboard in sycamore grey

Door armrests, centre console and knee pad in sycamore grey with contrasting stitching in brass gold

Door trim inserts in Alcantara, sycamore grey

Centre console and wood trim on the back of the front seats in fine grain ash, natural pearl grey

Carpet and floor mats in velour, sycamore grey

Upper inlay in fine grain ash, natural pearl grey

Lower inlay in brushed aluminium, silver

#### Additional equipment:

Metallic paint finish; for S8 also option of pearl-effect paint finish

Comfort centre armrest, front

Seat heating, front and rear

Seat ventilation and massage function, front

Comfort head restraints, rear

4-zone deluxe automatic air conditioning

Ambient lighting

Full-leather package including headlining and parcel shelf in Alcantara as well as electric sunblinds on the rear window and on the rear door windows

Extended aluminium look in the interior

design selection emblem in the door trims



#### Audi design selection Balao brown

The Audi design selection Balao brown includes the following:

Comfort seats in Valcona leather, Balao brown with accordion pleat, contrasting stitching and piping in snow white

Seat belts in black

Headlining, upper pillar trim and sun visors in Alcantara, snow white

Parcel shelf in Alcantara, Balao brown

Multifunction leather steering wheel in mocca brown with shift paddles

Selector lever in leather, mocca brown

Top side of dashboard in mocca brown with contrasting stitching in snow white or mocca brown

Underside of dashboard in Balao brown

Door armrests, centre console and knee pad in Balao brown with contrasting stitching in snow white

Door trim inserts in Alcantara, Balao brown

Centre console and wood trim on the back of the front seats in fine grain ash, natural balsamic brown

Carpet and floor mats in velour, Balao brown

Upper inlay in fine grain ash, natural balsamic brown

Lower inlay in brushed aluminium, silver

#### Additional equipment:

Metallic paint finish; for S8 also option of pearl-effect paint finish

Comfort centre armrest, front

Seat heating, front and rear

Seat ventilation and massage function, front

Comfort head restraints, rear

4-zone deluxe automatic air conditioning

Ambient lighting

Full-leather package including headlining and parcel shelf in Alcantara as well as electric sunblinds on the rear window and on the rear door windows

Extended aluminium look in the interior

design selection emblem in the door trims



## You have an exclusive character. So why shouldn't your Audi have one too?

That the Audi exclusive range aspires to exclusivity is already evident from its name. Selected décors and coloured leather can be combined with customised paint finishes from the large selection of Audi exclusive colours to suit your own personal preferences. So you can highlight your car's exceptional character to even better advantage.



If you want to find out more about the Audi exclusive equipment versions and quality standards, just scan this QR code using your smartphone. Or follow this link in your browser: [www.audi.com/exclusivefilm](http://www.audi.com/exclusivefilm)



**Audi A8 L with Audi exclusive customised paint finish in aurora blue, pearl effect**

Audi Sport cast aluminium wheels in 10-V-spoke design, size 9 J x 21 with 275/35 R 21 tyres<sup>1</sup>

Audi exclusive leather upholstery and trim (package 4) in Valcona leather, smoky blue/sand beige

Controls in Audi exclusive leather in smoky blue with contrasting stitching in sand beige

Audi exclusive seat belts in sand beige

Headlining in Audi exclusive Alcantara, sand beige

Inlays, steering wheel rim with wooden segments, selector lever and grab handles in Audi exclusive fine grain ash, nougat

Audi exclusive carpet and floor mats in sand beige with leather edging and stitching in smoky blue

Audi exclusive personalised door sill trims, front and rear





The model-specific standard and optional equipment can be found in the index from page 102 onwards. The fuel consumption and CO<sub>2</sub> emission figures can be found from page 96 onwards.

## Audi exclusive leather upholstery and trim.

Let your imagination run wild with leather upholstery and trim from Audi exclusive. Select the colour that is the perfect match for your vision from the huge range of leather colours available, and create your own personal colour scheme. For a coordinated interior, you can also customise various equipment details, such as the colour of the contrasting stitching, the carpet, the edging on the floor mats or the seat belts.



Controls in Audi exclusive leather, in chestnut brown

The model-specific standard and optional equipment can be found in the index from page 102 onwards.



A selection from the range of Audi exclusive leather; seat upholstery also available in Alcantara (except in crimson red)

## The Audi exclusive inlays.

Almost no other material can lend as much atmosphere as wood. When you run your fingers over a fine-pored inlay, you immediately sense the exclusivity and premium quality – and above all the time and effort needed to create objects of such exquisite refinement.



The model-specific standard and optional equipment can be found in the index from page 102 onwards.

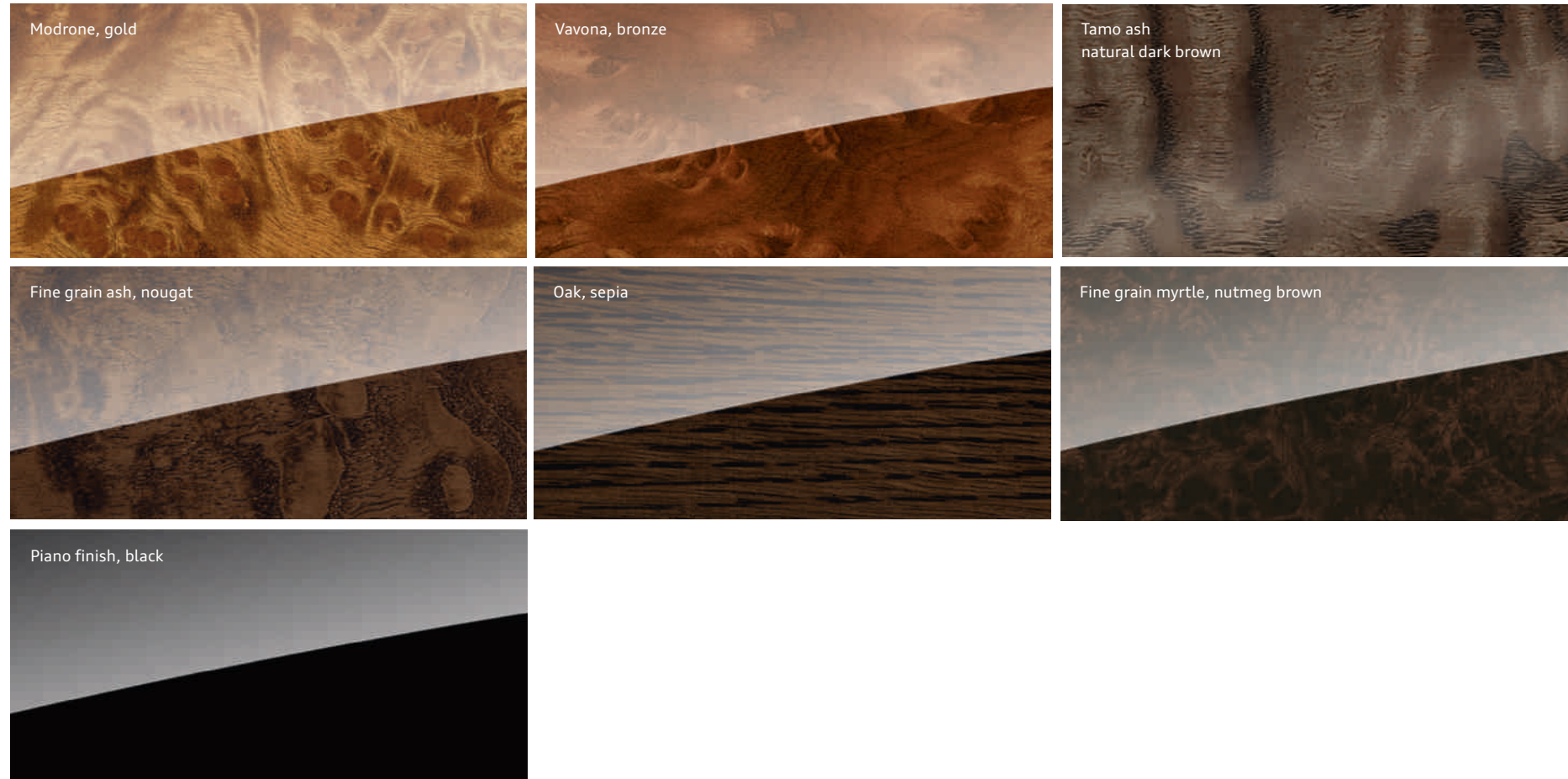

Selection from the range of Audi exclusive inlays

## The Audi exclusive paint colours.

You don't get a second chance to make a first impression. Seize this one and choose your own personal exterior paint finish from the large range of colours available from Audi exclusive.



- 1 Avus silver, metallic
- 2 Sand beige, pearl effect
- 3 Ipanema brown, metallic
- 4 Classic red, pearl effect
- 5 Palace blue, pearl effect
- 6 Saddle brown, pearl effect
- 7 Mamba black, metallic

Selection from the range of Audi exclusive paint finishes

## Individuality that stands out. The Audi exclusive design package plus.

An interior full of fascinating contrasts: with its high-quality leather upholstery and trim and exclusive colour scheme, the Audi exclusive design package plus creates an atmospheric ambience. Give expression to your personality by creating an interior design that is just like you: unique.



### Audi exclusive design package plus in granite grey/ calendula yellow

The Audi exclusive design package plus in granite grey/ calendula yellow includes the following:

- Seats including head restraints in Valcona leather, granite grey with contrasting stitching and piping in calendula yellow
- Centre console in Valcona leather, granite grey, comfort centre armrest and knee pad in Valcona leather, granite grey with contrasting stitching in calendula yellow
- Door trim inserts, lower door trims in Valcona leather, granite grey, door pull handles including door armrests in Valcona leather, granite grey with contrasting stitching in calendula yellow
- Multifunction leather steering wheel with airbag cover and steering column in granite grey with contrasting stitching in calendula yellow; stitching on steering wheel rim features specific Audi exclusive seam detail
- Top side and underside of dashboard including rail in leather, granite grey
- Carpet including floor mats in granite grey with leather edging in calendula yellow
- Audi exclusive parcel shelf in Alcantara, granite grey



The Audi exclusive design package plus from quattro GmbH.



## Your Audi is painted not just once. But four times.

When you choose a paint colour, choose one that best reflects your own personality. But whichever colour you opt for, you can count on the outstanding quality of our painting process. Though no thicker than a human hair, the layer of paint on an Audi is actually made up of four different coats. So not only do you look radiant in your Audi, the car is also optimally protected from environmental influences and wear. For its entire lifetime.



1 Floret silver, metallic

2 Glacier white, metallic

3 Cuvée silver, metallic

4 Daytona grey, pearl effect

5 Moonlight blue, metallic

6 Argus brown, metallic

7 Mythos black, metallic

Many more paint finishes can be found at [www.audi.com](http://www.audi.com)

## Quality given form. And a brilliant finish. Audi wheels.

To make sure you have peace of mind for every metre of your drive, Audi puts its wheels through an exacting series of specialised test procedures. Hardness tests, for example, aim for maximum stability, while a copper accelerated salt spray test – CASS for short – using acetic acid guarantees the greatest possible corrosion protection. Thanks to these and many other measures, we can ensure that every Audi wheel offers maximum quality – even after scores of kilometres. No matter which of the numerous designs you choose.



**1** 20" cast aluminium wheels  
in 10-spoke star design

**2** 20" Audi Sport cast aluminium wheels  
in 5-arm turbine design in magnesium look,  
gloss turned finish<sup>1,2</sup>

**3** 19" cast aluminium wheels  
in 10-spoke Y design, partly polished<sup>2</sup>

**4** 20" Audi Sport cast aluminium wheels  
in 5-spoke blade design,  
in matt titanium look, gloss turned finish<sup>1,2</sup>

**5** 20" forged aluminium wheels  
in 10-parallel-spoke design, partly polished<sup>2</sup>

**6** 21" Audi Sport cast aluminium wheels  
in 10-V-spoke design<sup>1</sup>

**7** 19" Audi Sport cast aluminium wheels  
in 7-twin-spoke design<sup>1</sup>

**8** 20" Audi Sport cast aluminium wheels  
in 5-twin-spoke design<sup>1</sup>

## Premium quality you can rely on.

You have a special place in your Audi. Exclusive comfort can be felt on the front and rear seats: thanks to high-quality materials and first-class workmanship. Regardless of which seat upholstery you choose, or whether you prefer the comfort seats or comfort sport seats for dynamic driving: you're sitting in the right place.



Comfort sport seats  
in Valcona leather, Vermont brown/granite grey  
The image shows the Audi design selection Vermont brown



Comfort seats in Valcona leather, sycamore grey  
The image shows the Audi design selection, sycamore grey

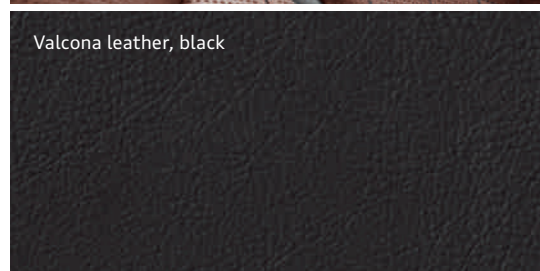

Valcona leather, black

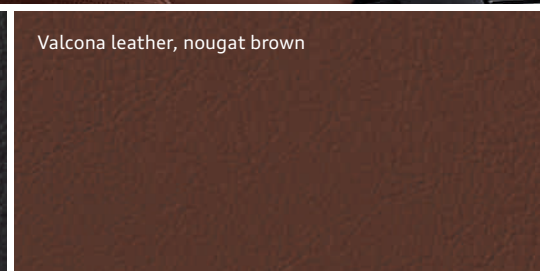

Valcona leather, nougat brown

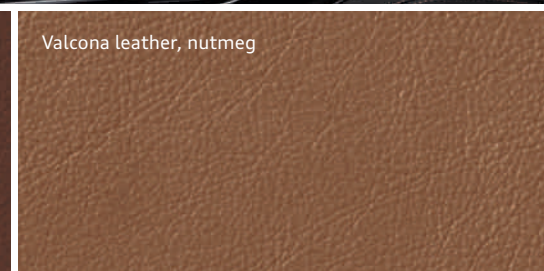

Valcona leather, nutmeg

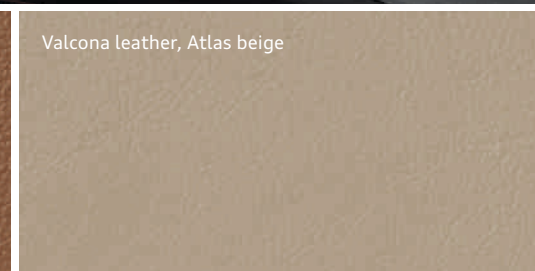

Valcona leather, Atlas beige

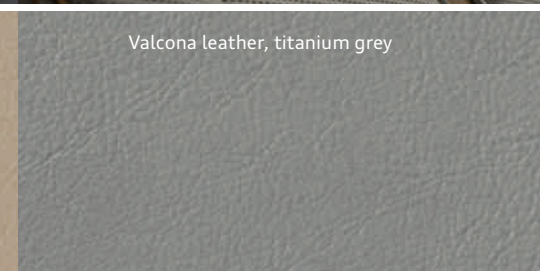

Valcona leather, titanium grey

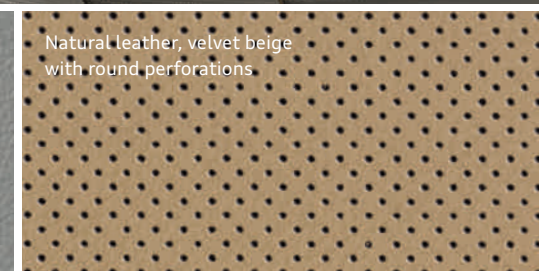

Natural leather, velvet beige  
with round perforations

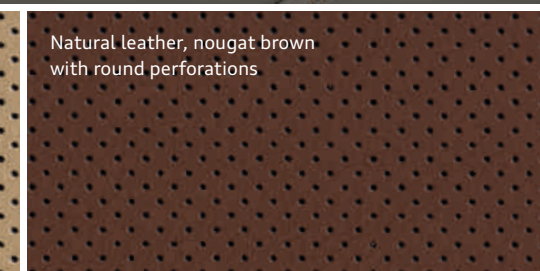

Natural leather, nougat brown  
with round perforations



Unicum leather, nutmeg with square perforations  
and diamond-patterned stitching

## Experience fascination. Down to the last detail.

Exclusive ambience is a question of style. Your style. A style you can refine down to the last detail. Create tangible accents with high-quality Audi inlays. Take pleasure in smooth wood that radiates a natural warmth. Experience the fascination of open-pore wood whose exclusivity you can literally feel. Or make a personal statement with combinations of fine woods and aluminium trim – and allow your own personal taste to determine the character.



Inlay in fine grain ash,  
natural pearl grey

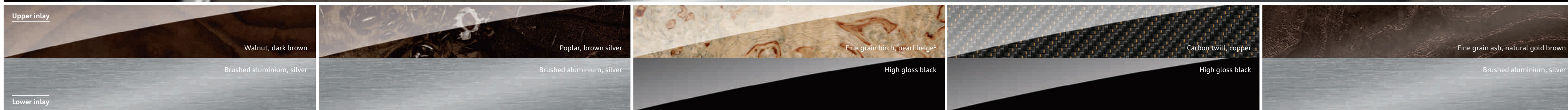

The model-specific standard and optional equipment can be found in the index from page 102 onwards.

¹From quattro GmbH.

Many more inlays can be found at [www.audi.com](http://www.audi.com)

## Audi Genuine Accessories. As individual as the life you lead.

An Audi is an expression of your personality. Audi Genuine Accessories builds on this concept in the truest sense of the word, with a range of high-quality products that are coordinated with your Audi. Noted for their perfect fit, safety and functionality. Making your model even more suited to you and your individual requirements. So that your Audi becomes your own personal Audi. These two pages contain just a small selection from the extensive range of Audi Genuine Accessories on offer.



**A8** Audi Genuine Accessories

Further information can be obtained from the Audi A8 accessories catalogue, at [www.audi.com](http://www.audi.com) and from your Audi partner.

### Ski and luggage boxes

New Audi design with improved aerodynamics thanks to a flat, sporty look Available in the colours platinum grey with brilliant black side blade and gloss brilliant black, each with chrome-plated Audi rings; high-quality look with no visible rivets. Can be locked and opened on both sides for convenient loading and unloading. With interior handle for closing the box. Simple quick-mounting system including torque limiting. Position moved forward for better access to the luggage compartment. Available in three sizes: 300 l, 360 l and 405 l. Can only be used in conjunction with the carrier unit.



### Luggage compartment shell

Made-to-measure luggage compartment protector; washable and sturdy. The lip around the edge helps ensure the luggage compartment floor is protected from any leaking fluids.

### Cast aluminium winter wheels in 7-arm design with snow chains<sup>1</sup>

Classic complete winter wheel in size 7.5 J x 17 with 235/60 R 17 tyres<sup>2</sup>. Recommended for better grip on snow and ice: snow chains from Audi Genuine Accessories.

### Audi child seat youngster plus

Offers excellent comfort thanks to intelligent belt guidance. The backrest is adjustable in height and width. Adaptations can be made via a viewing window for size adjustment. Suitable for children from 15 to 36 kg (approximately 4 to 12 years). Also available: Audi child seat for children from 9 to 18 kg (approx. 12 months to 4 years) and Audi baby seat for infants up to 13 kg (approx. 12 months). All child seats are available in the colours Misano red/black and titanium grey/black.

### Universal mobile phone holder

Allows low-radiation phone calls through connection to the external aerial and stores the mobile phone safely while driving. The mobile phone is placed conveniently into the universal holder and wirelessly connects with the external aerial of the vehicle. Can be used for many popular mobile phone models. There is therefore no need to change the adapter when you change mobile phones. Required: preparation for mobile phone (Bluetooth). The adapters, available separately for many popular mobile phone models, enable easy charging of your mobile phone's battery.

### Audi wireless internet access with LTE<sup>3</sup> (not shown)

For establishing an LTE internet connection using the vehicle's Wi-Fi network. Up to 100 Mbit/s data transfer; hotspot for up to 8 Wi-Fi-capable devices. Access up to 100 metres outside the vehicle is possible. Mobile internet access in other countries is possible either by using your domestic SIM card (after enabling it in the configuration menu) or by using a local prepaid SIM card.

<sup>1</sup> Please note the special information relating to wheels on page 98. <sup>2</sup> You will find specifications on the technical characteristics of tyres on page 99. <sup>3</sup> A mobile phone contract (not included) is required to use this feature. The fuel consumption and CO<sub>2</sub> emission figures can be found from page 96 onwards.



# The fascination of the Audi A8. Find out more online.

Discover the world of the Audi A8. More information more individuality and more exclusivity. Now at [www.audi.com](http://www.audi.com)



Scan the QR code using your smartphone or tablet and discover the world of the Audi A8.



Model	A8 3.0 TFSI quattro (228 kW)		A8 4.0 TFSI quattro (320 kW)		A8 3.0 TDI quattro (193 kW) <sup>1</sup>		A8 ultra 3.0 TDI quattro (193 kW) <sup>1</sup>		A8 4.2 TDI quattro (283 kW) <sup>1</sup>	
Engine type	V6 petrol engine with direct fuel injection and mechanical supercharger		V8 bi-turbo petrol engine with direct fuel injection, Audi valvelift system and Audi cylinder on demand		V6 diesel engine with common rail injection system and turbocharging		V6 diesel engine with common rail injection system and turbocharging		V8 diesel engine with common rail injection system and turbocharging	
Displacement in cc (valves per cylinder)	2,995 (4)		3,993 (4)		2,967 (4)		2,967 (4)		4,134 (4)	
Max. output <sup>2</sup> in kW at rpm	228/5,200–6,500		320/5,100–6,000		193/4,000–4,250		193/4,000–4,250		283/3,750	
Max. torque in Nm at rpm	440/2,900–4,750		600/1,500–5,000		580/1,750–2,500		580/1,750–2,500		850/2,000–2,750	
<b>Power transmission</b>										
Drive type	quattro permanent all-wheel drive		quattro permanent all-wheel drive		quattro permanent all-wheel drive		quattro permanent all-wheel drive		quattro permanent all-wheel drive	
Transmission type	8-speed tiptronic		8-speed tiptronic		8-speed tiptronic		8-speed tiptronic		8-speed tiptronic	
<b>Weights/capacities</b>	<b>A8</b>	<b>A8 L</b>	<b>A8</b>	<b>A8 L</b>	<b>A8</b>	<b>A8 L</b>	<b>A8</b>	<b>A8</b>	<b>A8 L</b>	
Unladen weight <sup>3</sup> in kg	1,905	1,955	1,995	2,050	1,955	2,010	1,955	2,115	2,170	
Gross vehicle weight in kg	2,520	2,530	2,570	2,625	2,570	2,585	2,570	2,705	2,720	
Permissible roof load limit/ nose weight in kg	100/95	100/95	100/95	100/95	100/95	100/95	100/95	100/95	100/95	
Trailer load limit <sup>4</sup> in kg unbraked	750	750	750	750	750	750	750	750	750	
12% gradient	2,300	2,300	2,300	2,300	2,200	2,200	2,200	2,300	2,300	
8% gradient	2,300	2,300	2,300	2,300	2,200	2,200	2,200	2,300	2,300	
Fuel tank capacity, approx. in l	82	82	82	82	82	82	82	82	82	
<b>Performance/consumption<sup>5</sup></b>										
Top speed in km/h	250 <sup>6</sup>	250 <sup>6</sup>	250 <sup>6</sup>	250 <sup>6</sup>	250 <sup>6</sup>	250 <sup>6</sup>	250 <sup>6</sup>	250 <sup>6</sup>	250 <sup>6</sup>	
Acceleration 0–100 km/h in s	5.7	5.9	4.5	4.6	5.9	6.1	5.9	4.7	4.9	
Fuel grade	Sulphur-free super RON 95 <sup>7</sup>		Sulphur-free super plus RON 98 <sup>8</sup>		Sulphur-free diesel <sup>9</sup>		Sulphur-free diesel <sup>9</sup>		Sulphur-free diesel <sup>9</sup>	
Fuel consumption <sup>10,11</sup> in l/100 km										
urban	10.2–10.0	10.2–10.0	12.8–12.4	12.8–12.5	7.5–7.3	7.7–7.4	7.2	9.7–9.4	9.8–9.5	
extra-urban	6.4–6.2	6.5–6.2	7.2–6.9	7.3–7.0	5.1–4.9	5.2–4.9	4.8	6.2–6.0	6.2–6.0	
combined	7.8–7.6	7.9–7.6	9.3–8.9	9.3–9.0	6.0–5.8	6.1–5.8	5.7	7.5–7.2	7.5–7.3	
CO <sub>2</sub> emissions <sup>10,11</sup> in g/km										
combined	178–173	179–174	214–206	215–207	157–151	161–153	149	196–189	197–190	
Emission standard	EU6	EU6	EU6	EU6	EU6	EU6	EU6	EU6	EU6	

Model	A8 L W12 6.3 FSI quattro (368 kW)	S8 4.0 TFSI quattro (382 kW)	S8 plus 4.0 TFSI quattro (445 kW)
Engine type	W12 petrol engine with direct fuel injection and Audi cylinder on demand	V8 bi-turbo petrol engine with direct fuel injection, Audi valvelift system and Audi cylinder on demand	V8 bi-turbo petrol engine with direct fuel injection, Audi valvelift system and Audi cylinder on demand
Displacement in cc (valves per cylinder)	6,299 (4)	3,993 (4)	3,993 (4)
Max. output <sup>2</sup> in kW at rpm	368/6,200	382/5,800	445/6,100–6,800
Max. torque in Nm at rpm	625/4,750	650/1,700–5,500	700/1,750–6,000 750/2,500–5,500 (in overboost)
<b>Power transmission</b>			
Drive type	quattro permanent all-wheel drive	quattro permanent all-wheel drive	quattro permanent all-wheel drive
Transmission type	8-speed tiptronic	8-speed tiptronic	8-speed tiptronic
<b>Weights/capacities</b>			
Unladen weight <sup>3</sup> in kg	2,150	2,065	2,065
Gross vehicle weight in kg	2,675	2,590	2,590
Permissible roof load limit/ nose weight in kg	100/95	100/95	100/95
Trailer load limit <sup>4</sup> in kg unbraked	750	750	750
12% gradient	2,300	2,300	2,300
8% gradient	2,300	2,300	2,300
Fuel tank capacity, approx. in l	82	82	82
<b>Performance/consumption<sup>5</sup></b>			
Top speed in km/h	250 <sup>6</sup>	250 <sup>6</sup>	250 <sup>6</sup>
Acceleration 0–100 km/h in s	4.6	4.1	3.8
Fuel grade	Sulphur-free super RON 95 <sup>7</sup>	Sulphur-free super plus RON 98 <sup>8</sup>	Sulphur-free super plus RON 98 <sup>8</sup>
Fuel consumption <sup>10,11</sup> in l/100 km			
urban	15.6–15.3	13.3–13.2	13.8–13.7
extra-urban	8.6–8.4	7.4–7.2	7.9–7.7
combined	11.2–11.0	9.6–9.4	10.0–9.9
CO <sub>2</sub> emissions <sup>10,11</sup> in g/km			
combined	259–254	220–216	231–229
Emission standard	EU6	EU6	EU6

### Explanatory notes















- <sup>1</sup> Refill the separate AdBlue®<sup>12</sup> tank as indicated by the information in the display of the instrument cluster. We recommend having the AdBlue tank refilled by your Audi partner.
- <sup>2</sup> The figure given was calculated using the specified measuring procedure (current version of UN-R 85).
- <sup>3</sup> Unladen vehicle weight includes driver (75 kg) and fuel tank 90 % full, calculated in accordance with the current version of Reg. (EU) 1230/2012. Optional equipment may increase the car's unladen weight and drag coefficient, whereupon the possible payload limit and the top speed will be reduced accordingly.
- <sup>4</sup> The engine's power output always decreases with increasing altitude. At 1,000 m above sea level, and for every additional 1,000 m, deduct 10 % from the weight of the outfit (trailer load limit + gross weight of the towing vehicle). Figure for trailer load limit applies to factory-fitted trailer towing hitch. If using the vehicle with a trailer towing hitch for commercial purposes, a digital tachograph may be required under certain conditions.
- <sup>5</sup> Fuel consumption and CO<sub>2</sub> emission figures given in ranges depend on the tyre/wheel sets used.
- <sup>6</sup> Regulated.
- <sup>7</sup> We recommend using sulphur-free super unleaded RON 95 fuel complying with DIN EN 228. If this is not available, use sulphur-free regular unleaded RON 91 fuel complying with DIN EN 228; power output will be slightly reduced. Unleaded RON 95 fuel with a maximum ethanol content of 10 % (E10) can generally be used. Fuel consumption details refer to operation with RON 95 fuel complying with 692/2008/EC.
- <sup>8</sup> We recommend using sulphur-free SuperPlus unleaded RON 98 fuel complying with DIN EN 228. If this is not available, use sulphur-free super unleaded RON 95 fuel complying with DIN EN 228; power output will be slightly reduced. Unleaded RON 95 fuel with a maximum ethanol content of 10 % (E10) can generally be used. Fuel consumption details refer to operation with RON 95 fuel complying with 692/2008/EC.
- <sup>9</sup> We recommend using sulphur-free diesel complying with DIN EN 590. If this is not available, use diesel complying with DIN EN 590.
- <sup>10</sup> The figures given were calculated using the specified measuring procedures. The figures do not refer to one individual vehicle and do not form part of any offer, but rather should be used purely for purposes of comparison between the different vehicle models.
- <sup>11</sup> A vehicle's fuel consumption and CO<sub>2</sub> emissions do not just depend on how efficiently the vehicle uses the fuel, but are also influenced by driving behaviour and other non-technical factors. CO<sub>2</sub> is the greenhouse gas primarily responsible for global warming.
- <sup>12</sup> Registered trademark of the Verband der Automobilindustrie e.V. (VDA).

### Important note

**Special information about the wheels:** Wheels with gloss turned finish as well as polished or partly polished aluminium wheels may not be used in wintry road conditions. For manufacturing reasons, the wheel rim surface does not have sufficient corrosion protection and it can be permanently damaged by road salt or similar.

### Classifications of tyre parameters

The table shows the range of fuel efficiency, wet grip and exterior noise emission classes for the different tyre sizes of the Audi A8, A8 L, A8 L W12, Audi S8 and Audi S8 plus.

	Tyre size	Fuel efficiency class	Wet grip class	Exterior noise emission class
Summer tyres	235/60 R 17	F–E	B	71 
	235/55 R 18	E–C	C–B	72–68  – 
	255/45 R 19	E	C–B	73–68  – 
	265/40 R 20	E–C	B	74–71  – 
	265/35 R 21	E	B	73 
Winter tyres	275/35 R 21	F–E	B	73–71 
	235/60 R 17	F–E	E	73–72  – 
	235/55 R 18	E–C	C–B	72–70 
	235/50 R 19	E	C	69 
	265/40 R 20	E	C	70 
	275/35 R 21	C	B	73 

It is not possible to order a specific tyre.  
Ask your Audi partner about the range of tyres available in your country.



Audi A8

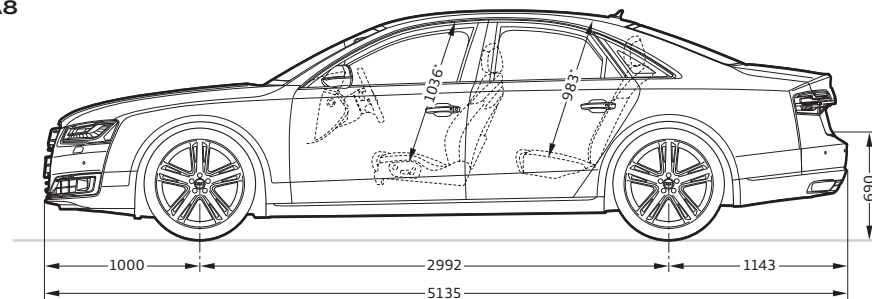

Audi A8 L/A8 L W12

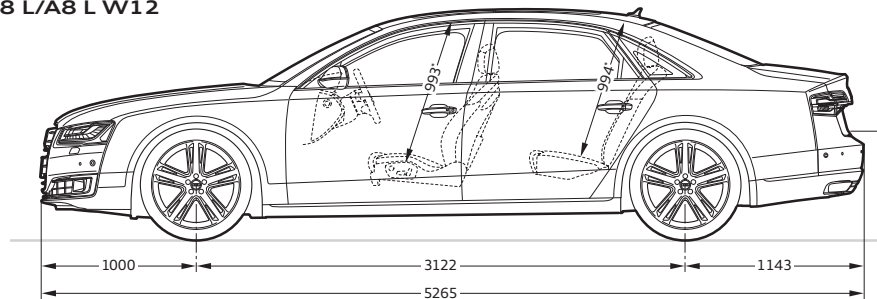

Audi S8/Audi S8 plus

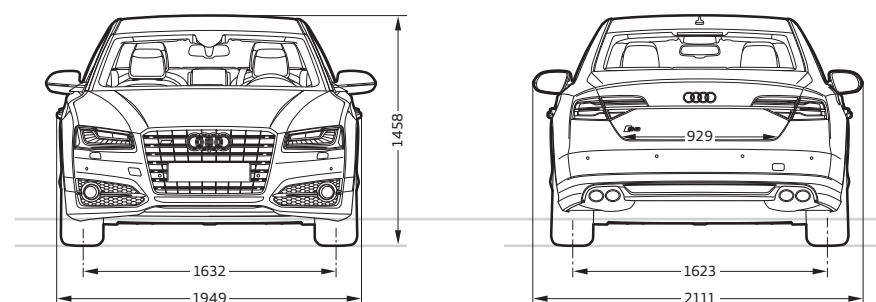
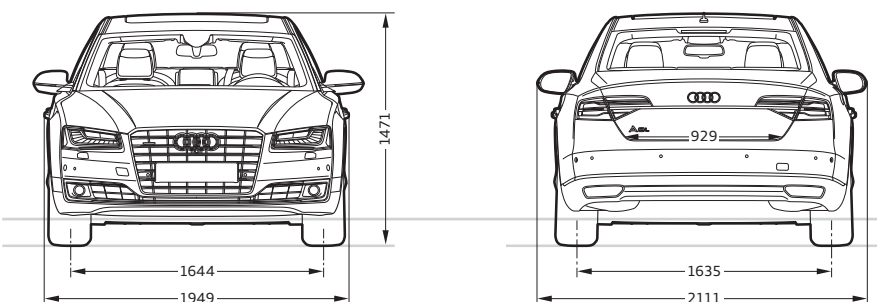
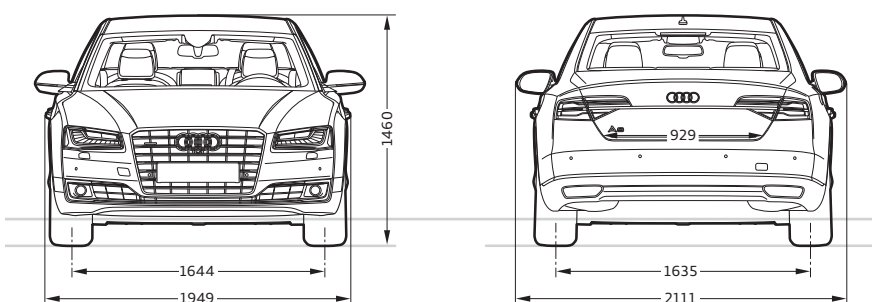
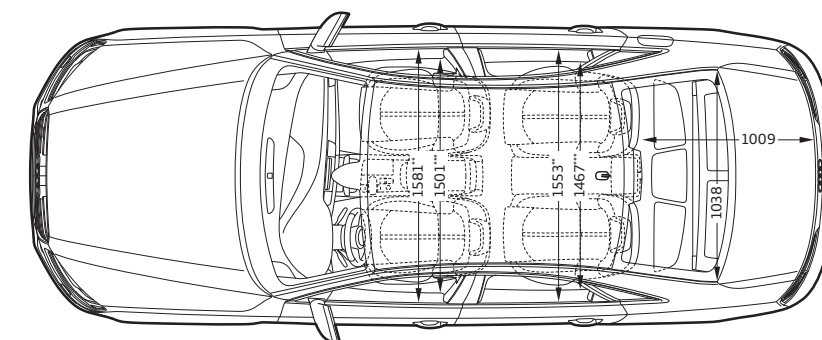
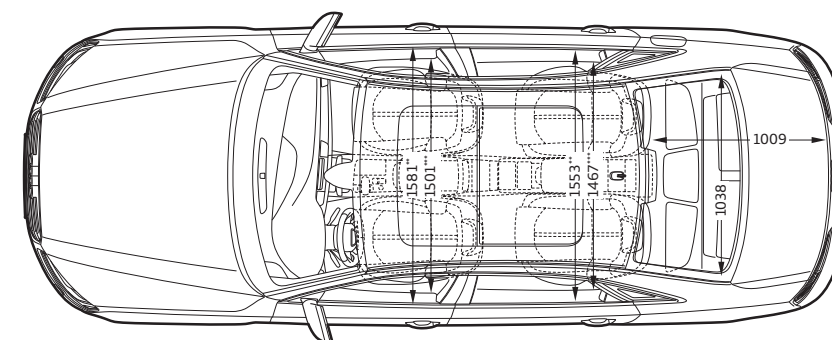
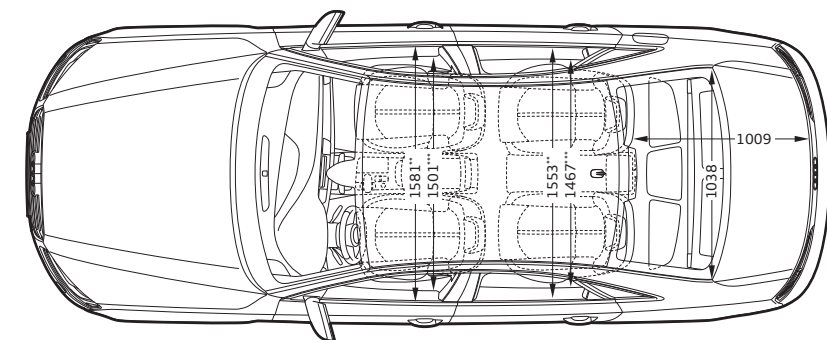
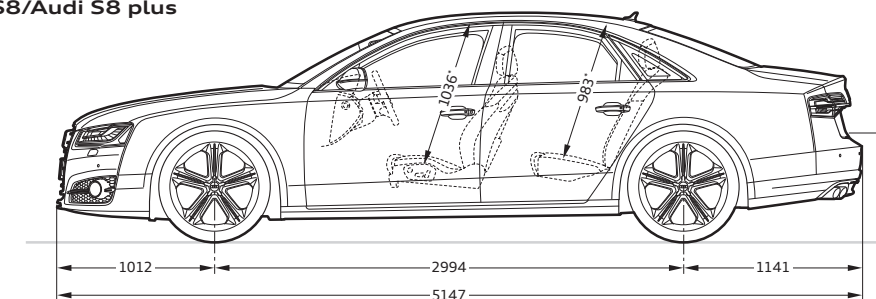
**Dimensions in millimetres.**

Dimensions are for unladen vehicle weight, ground clearance measured with vehicle carrying its maximum load. Luggage compartment volume<sup>1</sup> 520 l. Usable luggage space may be limited by optional equipment. Diesel models with AdBlue tank have 30 l less luggage space. Turning circle approx. 12.3 m.

\*Maximum headroom, depending on equipment. \*\*Elbow room width. \*\*\*Shoulder room width.

**Dimensions in millimetres.**

Dimensions are for unladen vehicle weight, ground clearance measured with vehicle carrying its maximum load. Luggage compartment volume<sup>1</sup> 520 l. Usable luggage space may be limited by optional equipment. Diesel models with AdBlue tank have 30 l less luggage space. Turning circle approx. 12.7 m.

\*Maximum headroom, depending on equipment. \*\*Elbow room width. \*\*\*Shoulder room width.

**Dimensions in millimetres.**

Dimensions are for unladen vehicle weight, ground clearance measured with vehicle carrying its maximum load. Luggage compartment volume<sup>1</sup> 520 l. Usable luggage space may be limited by optional equipment. Turning circle approx. 12.7 m.

\*Maximum headroom, depending on equipment. \*\*Elbow room width. \*\*\*Shoulder room width.

<sup>1</sup>Technical specifications refer to a basic vehicle without country-specific requirements and the selected optional equipment.

	A8	S8	S8 plus	A8 L	A8 LW12
<b>Lines and packages</b>					
Sport exterior package	■	–	–	■	–
Audi design selection Vermont brown	■	■	■	■	■
Audi design selection sycamore grey	■	■	■	■	■
Audi design selection Balao brown	■	■	■	■	■
Audi exclusive design package plus in granite grey/stitching in calendula yellow <sup>1</sup>	■	■	■	■	■
<b>Solid paint finishes</b>					
Ibis white	□	□	□	□	□
Brilliant black	□	□	□	□	□
<b>Metallic paint finishes</b>					
Mythos black, metallic	■	■	■	■	□
Havana black, metallic	■	■	■	■	□
Argus brown, metallic	■	■	■	■	□
Moonlight blue, metallic	■	■	■	■	□
Oolong grey, metallic	■	■	■	■	□
Monsoon grey, metallic	■	■	■	■	□
Cuvée silver, metallic	■	■	■	■	□
Floret silver, matt effect	–	–	■	–	–
Floret silver, metallic	■	■	■	■	□
Glacier white, metallic	■	■	■	■	□
<b>Pearl effect paint finish</b>					
Daytona grey, pearl effect	■ <sup>2</sup>	■	■	■ <sup>2</sup>	–
<b>Customised paint finishes</b>					
Audi exclusive customised paint finishes <sup>1</sup>	■	■	■	■	■

	A8	S8	S8 plus	A8 L	A8 LW12
<b>Wheels</b>					
17" forged aluminium wheels in 6-arm design	□ <sup>3</sup>	–	–	□ <sup>3</sup>	–
18" cast aluminium wheels in 10-spoke V design	□ <sup>4</sup>	–	–	□ <sup>4</sup>	–
19" cast aluminium wheels in 5-arm design	■	–	–	■	□
19" cast aluminium wheels in 10-spoke Y design, partly polished <sup>5</sup>	■	–	–	■	■
19" cast aluminium wheels in 15-spoke design, partly polished <sup>5</sup>	■	–	–	■	■
19" Audi Sport cast aluminium wheels in 5-V-spoke design in matt titanium look, gloss turned finish <sup>1,5</sup>	■	–	–	■	■
19" Audi Sport cast aluminium wheels in 7-twin-spoke design <sup>1</sup>	■	–	–	■	■
20" cast aluminium wheels in 10-spoke star design	■	–	–	■	■
20" forged aluminium wheels in 10-parallel-spoke design, partly polished <sup>5</sup>	■	–	–	■	■
20" cast aluminium wheels in 5-parallel-spoke design (S design)	–	□	–	–	–
20" forged aluminium wheels in 15-spoke structured design, contrasting grey, partly polished <sup>5</sup>	■	–	–	■	■
20" forged aluminium wheels in 15-spoke structured design, high gloss polished finish <sup>5</sup>	–	–	–	–	■
20" Audi Sport cast aluminium wheels in 5-twin-spoke design <sup>1</sup>	■	■	■	■	■

	A8	S8	S8 plus	A8 L	A8 LW12
20" Audi Sport cast aluminium wheels in 5-twin-spoke design in matt titanium look, gloss turned finish <sup>1,5</sup>	■	■	□	■	■
20" Audi Sport cast aluminium wheels in 5-spoke blade design <sup>1</sup>	■	■	–	■	■
20" Audi Sport cast aluminium wheels in 5-spoke blade design in matt titanium look, gloss turned finish <sup>1,5</sup>	■	■	■	■	■
20" Audi Sport cast aluminium wheels in 10-Y-spoke design <sup>1</sup>	■	■	–	■	■
20" Audi Sport cast aluminium wheels in 10-Y-spoke design in gloss black, gloss turned finish <sup>1,5</sup>	■	■	■	■	■
20" Audi Sport cast aluminium wheels in 5-arm turbine design in magnesium look, gloss turned finish <sup>1,5,6</sup>	■	■	–	■	■
21" cast aluminium wheels in 5-triple-spoke design (S design)	■ <sup>7</sup>	■	–	■ <sup>7</sup>	–
21" Audi Sport cast aluminium wheels in 10-V-spoke design <sup>1</sup>	■	■	■	■	■
21" Audi Sport cast aluminium wheels in 5-arm rotor design in matt titanium look, gloss turned finish <sup>1,5</sup>	■	■	■	■	■
21" Audi Sport cast aluminium wheels in 5-twin-arm design <sup>1</sup>	–	–	■	–	–
21" Audi Sport cast aluminium wheels in 5-twin-arm design in matt titanium look, gloss turned finish <sup>1,5</sup>	–	–	■	–	–
21" Audi Sport cast aluminium wheels in 5 twin-arm design in gloss anthracite black, gloss turned finish <sup>1,5</sup>	–	–	■	–	–
17" cast aluminium winter wheels in 6-arm design <sup>8</sup>	■	–	–	■	–

	A8	S8	S8 plus	A8 L	A8 LW12
18" cast aluminium winter wheels in 7-arm design <sup>8</sup>	■	–	–	■	–
19" cast aluminium winter wheels in 5-arm design <sup>8</sup>	■	■	■	■	■
20" cast aluminium winter wheels in 5-parallel-spoke design (S design) <sup>9</sup>	–	■	■	–	–
20" forged aluminium winter wheels in 10-parallel-spoke design <sup>9</sup>	■	–	–	■	■
21" Audi Sport cast aluminium winter wheels in 5-twin-arm design <sup>1,10</sup>	–	–	■	–	–
Tyre repair kit	□	□	□	□	□
Spare wheel, space-saving	■	■	■	■	■
Spare wheel with full-size tyre	■	–	–	■	■
Tyre pressure loss indicator	□	□	□	□	□
Anti-theft wheel bolts	□	□	□	□	□
Vehicle tool kit	□	□	□	□	□
Vehicle jack	■	■	■	■	■
<b>Seats for driver and front passenger</b>					
Standard seats, front	□	–	–	□	–
Comfort seats, front	■	■	■	■	□
Comfort seats, front with seat ventilation	■	■	■	■	■
Comfort sport seats, front	■	□	□	■	■
Comfort sport seats, front with seat ventilation	■	■	■	■	■

	A8	S8	S8 plus	A8 L	A8 LW12
<b>Seat upholstery for standard seats, front</b>					
Verdi cloth	□	–	–	□	–
Valcona leather, black	■	–	■	■	–
Valcona leather, velvet beige	■	–	■	■	–
<b>Seat upholstery for comfort seats, front</b>					
Valcona leather, black	■	■	■	■	□
Valcona leather, nougat brown	■	■	■	■	□
Valcona leather, nutmeg	■	■	■	■	□
Valcona leather, titanium grey	■	■	■	■	□
Valcona leather, velvet beige	■	■	■	■	□
Valcona leather, Atlas beige	■	■	■	■	□
Audi exclusive leather upholstery and trim <sup>1</sup>	■	■	■	■	■
<b>Seat upholstery for comfort seats, front with seat ventilation</b>					
Valcona leather, black	■	■	■	■	■
Valcona leather, nougat brown	■	■	■	■	■
Valcona leather, nutmeg	■	■	■	■	■
Valcona leather, titanium grey	■	■	■	■	■
Valcona leather, velvet beige	■	■	■	■	■
Valcona leather, Atlas beige	■	■	■	■	■
Valcona leather, Balao brown/snow white <sup>11</sup>	■	■	■	■	■
Valcona leather, sycamore grey/brass gold <sup>11</sup>	■	■	■	■	■
Natural leather, black	■	■	■	■	■
Natural leather, nougat brown	■	■	■	■	■
Natural leather, velvet beige	■	■	■	■	■
Audi exclusive leather upholstery and trim <sup>1</sup>	■	■	■	■	■

	A8	S8	S8 plus	A8 L	A8 LW12
<b>Seat upholstery for comfort sport seats, front with and without seat ventilation</b>					
Valcona leather, black	■	□	□	■	■
Valcona leather, black/stitching in Arras red	–	–	□	–	–
Valcona leather, nougat brown	■	□	■	■	■
Valcona leather, titanium grey	■	□	■	■	■
Valcona leather, lunar silver	–	□	■	–	–
Valcona leather, velvet beige	■	□	■	■	■
Valcona leather, Vermont brown/granite grey <sup>11</sup>	■	■	■	■	■
Unicum leather, nutmeg	■	■	■	■	■
Audi exclusive leather upholstery and trim <sup>1</sup>	■	■	■	■	■
<b>Leather packages</b>					
Leather package	■	□	□	■	–
Extended leather package	■	■	■	■	□
Full-leather package	■	■	■	■	■
Audi exclusive leather upholstery and trim (package 1) in Valcona leather <sup>1</sup>	■	■	■	■	■
Audi exclusive leather upholstery and trim (package 2) in Valcona leather <sup>1</sup>	■	■	■	■	■
Audi exclusive leather upholstery and trim (package 2) in Alcantara/Valcona leather <sup>1</sup>	■	■	■	■	■
Audi exclusive leather upholstery and trim (package 3) in Valcona leather <sup>1</sup>	■	■	■	■	■
Audi exclusive leather upholstery and trim (package 4) in Valcona leather <sup>1</sup>	■	■	■	■	■
Audi exclusive leather upholstery and trim (package 4) in Alcantara/Valcona leather <sup>1</sup>	■	■	■	■	■

	A8	S8	S8 plus	A8 L	A8 LW12
<b>Headlinings</b>					
Headlining in cloth	☐	☐	☐	☐	–
Headlining in cloth, black	■	■	■	■	–
Headlining and parcel shelf in Alcantara	■	■	■	■	☐
Headlining and parcel shelf in Alcantara, black	■	■	■	■	■
Headlining in Audi exclusive Alcantara <sup>1</sup>	■	■	■	■	■
Audi exclusive parcel shelf in Alcantara <sup>1</sup>	■	■	■	■	■
<b>Seating comfort</b>					
Seat heating, front	■	☐	☐	■	–
Seat heating, front and rear	■	■	■	■	☐
Seat ventilation, front <sup>12</sup>	■	■	■	■	■
Seat ventilation, front and rear <sup>12</sup>	■	■	■	■	■
Massage function, front <sup>12</sup>	■	■	■	■	■
Massage function, front and rear <sup>12</sup>	■	■	■	■	■
Centre armrest, front	☐	–	–	☐	–
Comfort centre armrest, front	■	☐	☐	■	☐
Memory function for the front seats	■	–	–	■	–
<b>Seats in the rear</b>					
Centre armrest, rear	☐	☐	☐	☐	☐
Comfort head restraints, rear	■	■	■	■	☐
Footrests, rear	–	–	–	■	■
Audi exclusive footrests, rear <sup>1</sup>	–	–	–	■	■
Rear seat package in sport seat look	■ <sup>13</sup>	■	■	■ <sup>13</sup>	■ <sup>13</sup>
Rear seat system	☐	☐	☐	☐	■
Individual seat package, rear	■	■	■	■	☐

	A8	S8	S8 plus	A8 L	A8 LW12
Individual seat package, rear with full-length, leather-covered centre console	–	–	–	■	■
Relaxation seat package, rear with full-length, leather-covered centre console	–	–	–	■	■
Extended comfort equipment, rear	–	–	–	■	■
<b>Upper/lower inlays</b>					
Walnut, dark brown/high gloss black	☐	■	■	☐	■
Vavona, Assam grey/high gloss black	■	■	■	■	■
Poplar, brown silver/high gloss black	■	■	■	■	■
Fine grain ash, natural gold brown/high gloss black	■	■	■	■	■
Piano finish, black <sup>1</sup> /high gloss black	■	■	■	■	■
Carbon Atlas/high gloss black	–	■	■	–	–
Carbon twill, copper/high gloss black <sup>11</sup>	■	■	■	–	–
Fine grain birch, pearl beige <sup>1</sup> /high gloss black	■	■	■	■	■
Fine grain ash, velvet brown <sup>1</sup> /high gloss black	■	■	■	■	■
Walnut, dark brown/brushed aluminium, silver	■	■	■	■	■
Vavona, Assam grey/brushed aluminium, silver	■	■	■	■	■
Poplar, brown silver/brushed aluminium, silver	■	■	■	■	■

	A8	S8	S8 plus	A8 L	A8 LW12
Fine grain ash, natural gold brown/brushed aluminium, silver	■	■	■	■	■
Piano finish, black <sup>1</sup> /brushed aluminium, silver	■	■	■	■	☐
Carbon Atlas/brushed aluminium, silver	–	☐	☐	–	–
Carbon twill, copper/brushed aluminium, silver <sup>11</sup>	■	■	■	–	–
Carbon twill, red <sup>1</sup> /brushed aluminium, silver	–	–	■	–	–
Fine grain ash, natural copper brown/brushed aluminium, silver <sup>11</sup>	■	■	■	■	■
Fine grain ash, natural balsamic brown/brushed aluminium, silver <sup>11</sup>	■	■	■	■	■
Fine grain ash, natural pearl grey/brushed aluminium, silver <sup>11</sup>	■	■	■	■	■
Fine grain birch, pearl beige <sup>1</sup> /brushed aluminium, silver	■	■	■	■	■
Fine grain ash, velvet brown <sup>1</sup> /brushed aluminium, silver	■	■	■	■	■
Audi exclusive inlays <sup>1</sup>	■	■	■	■	■
Grab handles with wooden segments	■	■	■	■	☐
Audi exclusive grab handles with wooden segments <sup>1</sup>	■	■	■	■	■
Aluminium look in the interior	☐	☐	☐	☐	–
Extended aluminium look in the interior	■	☐	☐	■	☐
<b>Headlights</b>					
Xenon plus	☐	–	–	☐	–
LED headlights	■	☐	☐	■	☐
Audi Matrix LED headlights	■	■	■	■	☐

	A8	S8	S8 plus	A8 L	A8 LW12
Light/rain sensor	☐	☐	☐	☐	☐
LED rear lights	☐	☐	☐	☐	☐
LED rear lights with dynamic indicator <sup>14</sup>	■	☐	■	■	☐
LED rear lights, dark-tinted	–	–	☐	–	–
Adaptive brake light	☐	☐	■	☐	☐
<b>Interior lighting</b>					
Interior and exterior lighting package	☐	☐	☐	☐	☐
Ambient lighting	■	☐	☐	■	☐
Additional reading lights in the rear	■	■	■	■	☐
Vanity mirrors and additional reading lights in the rear	–	–	■	■	☐
Audi exclusive cardan reading lights in the rear <sup>1</sup>	■	■	■	■	■
<b>Exterior design</b>					
Audi exclusive black styling package <sup>1</sup>	■	–	–	■	–
Model name/logo	☐	☐	☐	☐	☐
Rear spoiler in carbon	–	–	■	–	–
Audi Singleframe	☐	☐	☐	☐	–
Audi Singleframe, W12-specific with close-mesh honeycomb structure in chrome	–	–	–	–	☐
Diffuser insert at rear	–	☐	■	–	–
Diffuser insert in gloss black with carbon surround	–	–	■	–	–
Exhaust tailpipes, dual-branch design with trapezoidal chrome surrounds integrated into the bumper	☐	–	–	☐	☐
Exhaust tailpipes, dual-branch design, 2 oval chrome surrounds on both left and right	–	☐	■	–	–

	A8	S8	S8 plus	A8 L	A8 LW12
<b>Interior design</b>					
Analogue clock	☐	☐	☐	☐	☐
Floor mats, front and rear	☐	☐	☐	☐	☐
Audi exclusive floor mats <sup>1</sup>	■	■	■	■	■
Audi exclusive carpet and floor mats <sup>1</sup>	■	■	■	■	■
Pedals and footrest in stainless steel	–	☐	☐	–	–
Door sill trims with aluminium inlays	☐	–	–	☐	–
Door sill trims with aluminium inlays with model-specific illuminated logo	–	☐	☐	–	☐
Audi exclusive personalised door sill trims, front <sup>1</sup>	■	■	■	■	■
Audi exclusive personalised door sill trims, front and rear <sup>1</sup>	■	■	■	■	■
<b>Steering wheels/controls</b>					
Multifunction leather steering wheel in 4-spoke design with shift paddles	☐ <sup>15</sup>	■	■	☐ <sup>15</sup>	☐
Multifunction leather steering wheel in 4-spoke design with shift paddles, heated	■	■	■	■	■
Multifunction sport leather steering wheel in 3-spoke design with shift paddles	☐ <sup>16</sup>	☐	☐	☐ <sup>16</sup>	■
Multifunction sport leather steering wheel in 3-spoke design with shift paddles, heated	■	■	■	■	■
Electric steering wheel adjustment	☐	☐	☐	☐	☐
Selector lever in leather	☐	■	■	☐	☐
Selector lever in wood <sup>17</sup>	■	■	■	■	■
Audi exclusive selector lever in wood <sup>1</sup>	■	■	■	■	■
Selector lever in carbon Atlas	–	☐	☐	–	–
Selector lever in piano finish, black	–	■ <sup>18</sup>	■	–	☐

	A8	S8	S8 plus	A8 L	A8 LW12
Steering wheel rim with wooden segments <sup>1</sup>	■	■	■	■	■
Audi exclusive steering wheel rim with wooden segments <sup>1</sup>	■	■	■	■	■
Audi exclusive leather steering wheel <sup>1</sup>	■	■	■	■	■
Audi exclusive leather controls <sup>1</sup>	■	■	■	■	■
<b>Mirrors</b>					
Exterior mirrors with integrated LED indicator, electrically adjustable, heated and folding, including automatic kerb-side function for the exterior mirror on the passenger side	☐	–	–	☐	–
Exterior mirrors, additionally automatically dimming on both sides	■	–	–	■	–
Exterior mirrors additionally automatically dimming on both sides with memory function	■	☐	☐	■	☐
Exterior mirror housings in aluminium look	–	☐	☐	–	–
Exterior mirror housings in carbon	–	–	■	–	–
Exterior mirror housings in body colour with integrated chrome strip	–	–	–	–	☐
Interior mirror, automatically dimming	☐	☐	☐	☐	☐
Slide-and-tilt glass sunroof	■	■	■	☐	☐
Solar slide-and-tilt sunroof	■	■	■	■	■
Panoramic glass sunroof	–	–	–	■	■
<b>Glazing</b>					
Heat-insulating glass	☐	–	■	☐	–
Privacy glazing (dark-tinted windows)	■	■	■	■	■
Side and rear windows with insulating glass	■	■	■	■	☐

	A8	S8	S8 plus	A8 L	A8 LW12
<b>Glazing (continued)</b>					
Acoustic glazing	■	□	■	■	■
Climate-controlled comfort/acoustic glazing	■	■	■	■	□
Climate-controlled comfort/acoustic windscreen, heated wirelessly	■	■	■	■	■
Sunblind, electric for the rear window	■	■	■	-	-
Sunblinds, electric for the rear window and rear door windows	■	■	■	□	□
<b>Climate control</b>					
Deluxe automatic air conditioning	□	□	□	□	-
4-zone deluxe automatic air conditioning	■	■	■	■	□
Auxiliary heating/ventilation	■	■	■	■	■
Ioniser	■	■	■	■	■
<b>Closing systems</b>					
Remote control key	□	-	-	□	-
Engine start/stop button	□	□	□	□	□
Luggage compartment lid, automatically opening	□	□	□	□	□
Luggage compartment lid, electrically opening and closing	■	■	■	■	□
Convenience key with sensor-controlled release of the luggage compartment lid	-	□	□	■	□
Power-assisted door closing	■	■	■	■	□
Power-assisted closing for the luggage compartment lid	□	□	□	□	□
Garage door opener (HomeLink)	■	■	■	■	■
Anti-theft alarm	□	□	□	□	□
Preparation for tracking system	■	■	■	■	■

	A8	S8	S8 plus	A8 L	A8 LW12
<b>Storage/transport</b>					
Storage compartments	□	□	□	□	□
Cup holder	□	□	□	□	□
Luggage compartment package	■	■	■	■	■
Through-loading facility	■	■	■	■	■
Through-loading facility with removable ski/snowboard bag	■	■	■	■	■
Audi exclusive coolbox <sup>1</sup>	■	■	■	■	■
Non-smoker package	■	■	■	■	■
Cigarette lighter and ashtray	□	□	□	□	□
230V/115V/100V socket	■	■	■	■	■
Audi exclusive bar compartment <sup>1</sup>	-	-	-	■	■
Audi exclusive storage compartment <sup>1</sup>	-	-	-	■	■
Audi exclusive foldaway table <sup>1</sup>	■	■	■	■	■
Personalisation of the Audi exclusive foldaway table <sup>1</sup>	■	■	■	■	■
Provision for trailer towing hitch <sup>19</sup>	■	■	■	■	■
Trailer towing hitch, electrically swivelling	■	■	■	■	■
<b>MMI/navigation/display instruments</b>					
Instrument cluster	□	□	□	□	□
Driver information system with colour display	□	□	□	□	□
Attention assist	□	□	□	□	□
MMI	□	□	□	□	-
MMI navigation plus with MMI touch	■	■	■	■	□

	A8	S8	S8 plus	A8 L	A8 LW12
Navigation data (hard drive)	■	■	■	■	□
Head-up display	■	■	■	■	■
<b>Entertainment</b>					
MMI radio plus	□	□	□	□	□
Digital Audio Broadcasting	■	■	■	■	■
DVD changer	■	□	□	■	□
Audi sound system	□	□	□	□	-
Bose Surround Sound	■	■	■	■	□
Bang & Olufsen Advanced Sound System	■	■	■	■	■
Audi music interface	■	■	■	■	□
Rear Seat Entertainment	■	■	■	■	■
<b>Communication</b>					
Audi connect including car phone <sup>20</sup>	■	■	■	■	□
Audi phone box <sup>21</sup>	■	■	■	■	-
Bluetooth interface	■	■	■	■	□
Mobile phone holder in the rear	-	-	■	-	□
Handset in the front for car phone	■	■	■	■	□
Handsets in the front and rear for car phone	■	■	■	■	■
<b>Assistance systems</b>					
Hold assist <sup>22</sup>	□	□	□	□	□
Parking system plus <sup>22</sup>	■	□	□	■	□
Park assist <sup>22</sup>	■	■	■	■	■
Reversing camera <sup>22</sup>	■	■	■	■	□
360 degree cameras <sup>22</sup>	■	■	■	■	■
Cruise control <sup>22</sup>	□	□	□	□	□

	A8	S8	S8 plus	A8 L	A8 LW12
Audi pre sense basic <sup>22</sup>	□	□	□	□	□
adaptive cruise control with Stop&Go function including Audi pre sense front <sup>22</sup>	■	■	■	■	■
Audi side assist including Audi pre sense rear <sup>22</sup>	■	■	■	■	■
Audi active lane assist <sup>22</sup>	■	■	■	■	■
Assistance package including Audi pre sense plus <sup>22</sup>	■	■	■	■	■
Night vision assistant <sup>22</sup>	■	■	■	■	■
Camera-based speed limit display <sup>22</sup>	■	■	■	■	■
<b>Driving dynamics/brakes</b>					
Audi drive select	□	□	□	□	□
adaptive air suspension	□	-	-	□	□
adaptive air suspension sport	■	□	□	-	-
quattro	□	-	-	□	□
quattro with sport differential	■ <sup>16</sup>	□	□	■ <sup>16</sup>	■
tiptronic	□	□	□	□	□
Electromechanical power steering	□	-	-	□	□
Dynamic steering	■	□	□	■	■
Dynamic package	-	-	■	-	-
Multicollision brake assist system	□	□	□	□	□
Brake system	□	□	□	□	□
Brake callipers, painted black	-	□	■	-	□
Ceramic brake <sup>23</sup>	■ <sup>24</sup>	■	■	■ <sup>24</sup>	■
Electromechanical parking brake	□	□	□	□	□
<b>Technology/safety</b>					
Active Noise Cancellation	□ <sup>25</sup>	□	□	□ <sup>25</sup>	□
Audi Space Frame (ASF) body	□	□	□	□	□

	A8	S8	S8 plus	A8 L	A8 LW12
Antilock Brake System (ABS) with Electronic Brake Force Distribution (EBD)	□	□	□	□	□
Anti-Slip Regulation (ASR)	□	□	□	□	□
Electronic differential lock (EDL)	□	□	□	□	□
Electronic Stabilisation Control (ESC)	□	□	□	□	□
Sport exhaust system	-	■	■	-	-
Recuperation	□	□	□	□	□
Start-stop system	□	□	□	□	□
Audi cylinder on demand	□ <sup>26</sup>	□	□	□ <sup>26</sup>	□
Audi TDI clean diesel	□ <sup>27</sup>	-	-	□ <sup>27</sup>	-
Misfuelling protection	□ <sup>27</sup>	-	-	□ <sup>27</sup>	-
Airbags	□	□	□	□	□
Side impact protection	□	□	□	□	□
Integrated head restraint system	□	□	□	□	□
Deactivation switch for front passenger airbag	■	■	■	■	■
Seat belts	□	□	□	□	□
Audi exclusive seat belts <sup>1</sup>	■	■	■	■	■
ISOFIX child seat mounting and top tether for the outer rear seats	□	□	□	□	□
First-aid kit	□	□	□	□	□
Warning triangle	□	□	□	□	□
Warning and control lights	□	□	□	□	□
<b>Audi Extended Warranty</b>					
Audi Extended Warranty	■	■	■	■	■

Equipment for the Audi A8 illustrated (p. 4–13):

Paint finish: floret silver, metallic

Wheels: cast aluminium wheels in 10-spoke star design

Seats/seat upholstery: comfort seats, front in Valcona leather, Atlas beige

Inlays: upper inlay in poplar, brown silver;

lower inlay in high gloss black; extended aluminium look in the interior

Equipment for the Audi A8 L illustrated (p. 14–17):

Paint finish: Oolong grey, metallic

Wheels: forged aluminium wheels in 10-parallel-spoke design, partly polished<sup>5</sup>

Seats/seat upholstery: comfort seats, front in unicum leather, nutmeg

Inlays: upper inlay in walnut, dark brown;

lower inlay in brushed aluminium, silver

Equipment for the Audi A8 L W12 illustrated (p. 18–23):

Paint finish: mythos black, metallic

Wheels: forged aluminium wheels in 15-spoke structured design, high gloss polished finish<sup>5</sup>

Seats/seat upholstery: comfort seats, front in Valcona leather, velvet beige

Inlays: upper inlay in fine grain ash, natural gold brown;

lower inlay in brushed aluminium, silver; extended aluminium look in the interior

Equipment for the Audi S8 illustrated (p. 24–31):

Paint finish: Daytona grey, pearl effect

Wheels: cast aluminium wheels in 5-triple-spoke design (S design)

Seats/seat upholstery: comfort sport seats, front in Valcona leather, Vermont brown/granite grey (Audi design selection)

Inlays: upper inlay in carbon twill, copper;

lower inlay in brushed aluminium, silver; extended aluminium look in the interior;

headlining and parcel shelf in Alcantara, black

Equipment for the Audi S8 plus illustrated (p. 32–37):

Paint finish: floret silver, matt effect

Wheels: Audi Sport cast aluminium wheels in 5-twin-arm design in gloss anthracite black, gloss turned finish<sup>1,5</sup>

Seats/seat upholstery: comfort sport seats, front in Valcona leather, black, with contrasting stitching and piping in Arras red

Inlays: carbon twill, red

#### Legal information about Audi connect

Use of the services supported by Audi connect is possible only with the optional MMI navigation plus with MMI touch and Audi connect including car phone. You also require a SIM card with data option – with car phone a SIM card with phone and data option or a Bluetooth-capable smartphone<sup>21</sup> with remote SIM Access Profile (rSAP). There is a reader for your SIM card in the panel of the MMI navigation plus with MMI touch. The services are available only in conjunction with an existing or separate mobile phone contract and only within the range of the respective mobile phone network. Additional costs may be incurred when receiving data packets from the internet, depending on the terms of your mobile phone contract, particularly when used abroad. Because of the high data volumes involved, a data flat rate is strongly recommended.

The availability of the services supported by Audi connect varies from country to country. Audi connect services are available for at least 1 year from vehicle delivery. After the 24 months have expired, the Audi connect services will be extended free of charge once for 12 months. If you do not require this free of charge extension, please notify us by writing to the following address:

AUDI AG

Audi International Customer Care Services

85045 Ingolstadt, Germany

Email: [kundenbetreuung@audi.de](mailto:kundenbetreuung@audi.de)

Tel: +49 (0) 800-2834 7378423

Ask your Audi partner about a subsequent extension of the Audi connect services.

Please visit [www.audi.com/connect](http://www.audi.com/connect) or contact your Audi partner for more detailed information about Audi connect; contact your mobile services provider for information about contract conditions.

Standard equipment

Optional equipment

Standard/optional equipment varies by model

— Not available

Country-specific variations possible. Please find out from your local Audi partner which equipment is standard and what optional equipment is available in your country.

<sup>1</sup> From quattro GmbH.

<sup>2</sup> Only available in conjunction with the sport exterior package.

<sup>3</sup> Standard for 6-cylinder models.

<sup>4</sup> Standard for 8-cylinder models.

<sup>5</sup> Please note the special information relating to wheels on page 98.

<sup>6</sup> For information on when this feature will be available, please contact your Audi partner.

<sup>7</sup> Only available in conjunction with the 3.0 TDI quattro and sport exterior package.

<sup>8</sup> Permissible top speed 210 km/h, can be fitted with snow chains.

<sup>9</sup> Permissible top speed 240 km/h, cannot be fitted with snow chains.

<sup>10</sup> Permissible top speed 270 km/h, can be fitted with snow chains.

<sup>11</sup> Can only be ordered in conjunction with Audi design selection.

<sup>12</sup> Only available in conjunction with comfort seats, front or comfort sport seats, front.

<sup>13</sup> Only available in conjunction with comfort sport seats, front.

<sup>14</sup> Only available in conjunction with LED headlights or Audi Matrix LED headlights.

<sup>15</sup> Standard for 6-cylinder models and 4.0 TFSI.

<sup>16</sup> Standard for 4.2 TDI quattro.

<sup>17</sup> Cannot be ordered in conjunction with inlays specified as natural.

<sup>18</sup> Only available in conjunction with the Audi design selection Vermont brown.

<sup>19</sup> The trailer towing hitch for retrofitting is available from Audi Genuine Accessories.

<sup>20</sup> Legal information and notes on use can be found on this page.

<sup>21</sup> Please contact your Audi partner or visit [www.audi.com/bluetooth](http://www.audi.com/bluetooth) for information on compatible mobile phones.

<sup>22</sup> Please note: The systems work only within system limits and assist the driver. However, the driver remains responsible for driving the vehicle and is required to be attentive at all times.

<sup>23</sup> Please consult your Audi partner or national Audi website to find out more about the special features of the ceramic brake.

<sup>24</sup> Only available for 8-cylinder models.

<sup>25</sup> Standard for 4.0 TFSI quattro.

<sup>26</sup> Only available for 4.0 TFSI quattro.

<sup>27</sup> Only available for TDI models.

**AUDI AG**  
85045 Ingolstadt  
www.audi.com  
Valid from April 2016

Printed in Germany  
633/1150.82.18

The models and equipment versions illustrated and described in this brochure and some of the services listed are not available in all countries. Some of the cars illustrated are equipped with optional features for which an extra charge is made. Details concerning the delivery specifications, appearance, performance, dimensions and weights, fuel consumption and running costs of the vehicle were correct to the best of our knowledge at the time of going to press. Deviations from the colours and shapes shown in the illustrations may occur. No liability is accepted for errors and printing errors. The right to introduce modifications is reserved. Not to be reproduced, including in part, without the written approval of AUDI AG.

This brochure is printed on paper made from pulp bleached without the use of chlorine.

